

SEGA®



• 100% Jamma Compatible

Installation/Owners Manual

Shadow Dancer Conversion

by:

SEGA Enterprises, Inc. (U.S.A.)

2149 Paragon Drive
San Jose, California 95131
Phone Number (408) 435-0201
FAX Number (408) 435-0294

Kit for
Design Cabinet with Horizontal Monitor

The Federal Communication Commission requires the verification of game kits. This game kit will meet these requirements when installed in accordance with the instructions in this Manual and using only components and materials supplied with this kit.

Table of Contents

Introduction	1
Handling and Installation Precautions	1
Prevention of Counterfeiting and Conversion Labeling	1
Precautions Concerning the Place of Installation	1
System Requirements	2
Tools Required	3
Cabinet Preparation	3
Kit Component Verification	4
Installation Procedure	5
Monitor Bezel	5
License Seal	5
Side Decal	5
Marquee Plex	5
Control Panel	5
Service Switch Assembly	6
Harness Installation	7
Cabinet 115 VAC System Grounding	9
Cabinet System Checkout	9
Shadow Dancer Printed Circuit Board Installation	9
Logic Board and Complete System Checkout	9
In Case of Difficulty	11
Figure 1	13
Figure 2	14
Figure 3	15
Figure 4	15
Figure 5	16
Figure 6	17
Figure 7	17
Figure 8	18
Figure 9	18
Figure 10	18
Figure 11	19
Figure 12	19
Figure 13	20
Switch Setting Sheet	21
Schematic Diagram	22

Introduction

SEGA ENTERPRISES, LTD., supported by its high electronic technology of Large Scale Integration, microprocessors, etc. and a wealth of experience, has for more than 30 years been supplying various innovative and popular game machines to the world market. This OWNER'S AND KIT INSTALLATION manual is intended to provide detailed comments together with all the necessary information covering the operation and installation of electronic assemblies, electromechanical assemblies, control assemblies, and spare or replacement parts for the Shadow Dancer coin operated game. This manual is intended for those who have knowledge of electricity and technical expertise in video games. Carefully read the enclosed information before starting the kit installation or troubleshooting procedures.

Handling and Installation Precautions

- During installation:**
1. Be sure to remove power plug when working on the machine.
 2. Be sure all connections and harness routing are secure.
 3. Make sure all grounding connections are secure and properly affixed.
 4. Do not use any fuse that does not meet the specified rating.

Prevention of Counterfeiting and Conversion Labeling

To prevent counterfeit and unauthorized conversions, the following label is supplied with all authorized SEGA kit products. When handling such goods, be sure to locate and confirm the label. It is used to prevent illegal acts such as the unauthorized copying of the products and the printed circuit boards.



Precautions Concerning the Place of Installation

The Shadow Dancer CONVERSION KIT is intended to be installed in an indoor game cabinet. Absolutely do not install it outdoors. When installed indoors the following places mentioned below should be avoided to ensure proper operation and usage:

- Places subject to rain or water leakage, or condensation due to humidity
- In the proximity of an indoor swimming pool and/or shower
- Places subject to direct sunlight
- Places subject to heat sources from heating units, hot air, etc.
- Vicinity of highly flammable/volatile chemicals or hazardous materials
- Sloped surfaces
- Vicinity of anti-disaster facilities such as fire exits and fire extinguishers
- Places subject to any type of violent impact
- Dusty environment

System Requirements

Power Supply:

- Input voltage 90 VAC to 135 VAC 60 Hz
- + 5 volts at 6 amps
- + 12 volts at 2 amps
- Overvoltage protected at + 5.8 volts
- Current limit set at 8 amps

RFI Line Filter:

1. If a switching power supply is used:
 - Current rating of 6 amps
 - Frequency attenuation of the following:

.15 MHz	40db
.5 MHz	65db
1.0 MHz	65db
5.0 MHz	55db
10.0 MHz	50db
30.0 MHz	50db
2. If a linear power supply is used:
 - Current rating of 5 amps
 - Frequency attenuation of the following:

.15 MHz	6db
.5 MHz	19db
1.0 MHz	28db
5.0 MHz	42db
10.0 MHz	45db
30.0 MHz	50db

Miscellaneous:

Line Fuse: 4 amp 120 VAC
Speaker: 8 ohms 10 watt
On/Off Switch: 6 amp 120 VAC
Isolation Transformer: 115 VAC primary, 115 VAC secondary, 100 watts
Coin Door: Dual coin acceptors
Coin Meter: + 5 Volt DC
Power Cord: Three conductor with ground
Color Monitor:

- Video input 1 volt to 5 volt peak-to-peak positive polarity
- Sync TTL negative polarity separate horizontal and vertical
- Horizontal frequency 15.750 KHz
- Vertical frequency 60 Hz
- Video bandwidth 12MHz or greater
- Horizontal mounted
- Recommended size 19 inch

Tools Required

- Drill
- Hole cutter 1-3/16"
- Phillips screw driver
- Flat blade screw driver
- Small flat blade screw driver
- Scissors
- Sand paper
- Paint
- X-acto knife
- Wood patch

Cabinet Preparation

1. Remove old PCB, and all existing game harnesses.
2. Remove and disassemble the control panel.
3. Remove any side decals, monitor bezel, and marquee.
4. Using sandpaper and/or paint thinner, clean and smooth the cabinet for paint preparation. Use wood patch to fill any knicks or flaws in the cabinet.
5. Paint cabinet if required.
6. Wipe down and vacuum cabinet as necessary.

NOTE: You are building a new game, not just changing an old one. A nice, clean, and new looking conversion not only earns better, but lasts longer.

Kit Component Verification

Verify each component with the kit list provided to assure your kit is complete. If any part is missing after the inventory is taken, please contact your distributor, and provide to them the following information:

1. Kit serial number
2. Part number and description of missing item/s
3. Date received

Kit List

Part Number	Quantity	Description
0002-0000	2	#6 x 3/8 P/h Phil Tek
0002-0001	4	#6 x 3/4 P/H Phil "AB" SMS
0312-0024	4	#10-24 x 1 3/4 Carr/Bolt Black
0502-0024	4	#10-24 Hexnut
0612-0024	4	#10 Split Lock Washer
0692-0024	4	#10 Flat Washer 1/2 OD
2112-0000	2	Wire Nut #18 x 2
252-0008U	1	Monitor Bezel Shadow Dancer
420-0010U	1	Manual Shadow Dancer
421-5801-103	1	License Seal Shadow Dancer
4212-0001	1	(Kit) Serial # Sticker
423-0048U	1	Shadow Dancer Marquee Plex
423-0047U	2	Side Decal, Shadow Dancer
423-0051U	1	Shadow Dancer Control Panel Overlay
423-0008-01	1	Control Panel Clear Plex
423-0046U	1	Shadow Dancer Label Sheet (See List)
		(1) Test, Service, Volume Sticker
		(1) Joystick Sticker
		(2) Attack Stickers
		(2) Jump Stickers
		(2) Ninja Magic Stickers
		(1) Start 1 Player Sticker
		(1) Start 2 Player Sticker
		(1) FCC Sticker (Kit)
4750-0049	1	Volume Control 100 Ohm 10 Watt
5090-5028	2	PB Spst Switch Momentary
5091-0001-01	1	Joy Stick 8 Way (Spring Type)
5091-0004-01	2	PB Spst Control Panel (Red)
5091-0004-02	2	PB Spst Control Panel (White)
5091-0004-03	2	PB Spst Control Panel (Blue)
5091-0004-04	2	PB Spst Control Panel (Yellow)
6010-0043	1	Knob, 1/8" Shaft
833-7246-01	1	Shadow Dancer Game—PCB
9992-0000	6	4" Tie Wrap
KRO-1721	1	Service Switch Bracket
JAM-0000	1	JAMMA HARNESS
5091-0015-01	8	Pal Nut
5091-0015-02	8	Leaf Switch
5091-0015-03	8	Universal Adaptor

Installation Procedure

- | | |
|----------------------|---|
| Monitor Bezel | 1. Locate MONITOR BEZEL (252-0008U). Measure the size of existing monitor bezel or the required size to fit and cut cardboard monitor bezel to size. (see figure 1) |
| License Seal | 2. Locate Shadow Dancer LICENSE SEAL (421-5801-103) and place seal as shown of in figure 1. Install Monitor Bezel on game cabinet. Note: Verify that the License Seal will be visible when the bezel is installed on game cabinet. |
| Side Decal | 3. Locate Shadow Dancer SIDE ART (423-0047U). Install on the left and right side panels of the cabinet (see figure 1). Note: A mixture of slightly soapy water can be used on the cabinet to position the artwork as desired. A squeegee may be used to remove any wrinkles in the artwork if soapy water is used. |
| Marquee Plex | 4. Locate Shadow Dancer MARQUEE PLEX (423-0048U). Measure the size of existing marquee plex or required size to fit and trim the marquee plex to size. Install on cabinet. (see figure 1) |
| Control Panel | 5. Locate Shadow Dancer CONTROL PANEL OVERLAY (423-0051U). Measure the size required and cut the control panel overlay to fit the existing control panel.
6. Define the location of the player push buttons and joystick(s) on the control panel. (see figure 2)
7. Cut holes in control panel to locate buttons and joystick(s). See template for button and joystick. (see figure 3)
8. Install the "ONE PLAYER START" label and the "TWO PLAYER START" label on the control panel overlay. (see figure 2)
9. Install player control button labels, Attack, Jump and Ninja Magic on the control panel overlay. (see figure 2)
10. Install the JOYSTICK label on the control panel overlay. (see figure 2)
11. Locate the CONTROL PANEL CLEAR PLEX (423-0008-01) and cut holes into the plex to match the holes cut into the control panel. Then trim as required to protect the control panel overlay and labels. Note: this clear plex overlay can be used to protect unused holes in the control panel from player punctures. (see figure 2)
12. Install YELLOW buttons (5091-0004-04) in the "Ninja Magic" locations. (see figure 2)
13. Install RED buttons (5091-0004-01) in the "Attack" locations. (see figure 2) |

14. Install BLUE buttons (5091-0004-03) in the "Jump" locations. (see figure 2)
15. Install WHITE buttons (5091-0004-02) in 1 PLAYER START and 2 PLAYER START locations. (see figure 2)

NOTE: When buttons are securely placed and tightened in the control panel assembly, a small amount of clear RTV Silicone may be placed on two or three areas of the lock-nut to keep the switches from being unscrewed from the top of the panel. (see figure 3)

16. Locate the JOYSTICK (5091-0001-01). This package consists of the following six components.
 - a. Preassembled joystick base assembly with microswitches
 - b. E-ring
 - c. Black knob & shaft
 - d. 2" Dia. washer
 - e. Actuator plastic
 - f. Pivot cone

The final assembly of the joystick must be performed after the joystick base assembly is mounted on the control panel. Locate the following:

- | | |
|---|--------|
| a. #10-24 X 1 3/4 Carr/Bolt Black (0312-0024) | (4 ea) |
| b. #10-24 Hexnut (0502-0024) | (4 ea) |
| c. #10 Flat Washer 1/2" OD (0692-0024) | (4 ea) |
| d. #10 Split Lock Washer (0612-0024) | (4 ea) |

Use the above components to secure the Joystick base assembly to the control panel. (see figure 2)

The final assembly of the joystick is performed by:

- a. Placing the 2" Dia. washer over the Black knob & shaft.
- b. Install the Pivot cone on the shaft.
- c. Install the Black knob & shaft assembly through the joystick base assembly on the control panel.
- d. Install the Actuator micro/switch on the shaft.
- e. Install the E-ring on the shaft to secure the assembly.

Service Switch Assembly

17. Locate SERVICE SWITCH BRACKET (KR0-1721) and install two PUSH BUTTON SPST SWITCH MOMENTARY (5090-5028) into bracket as shown in figure 4.
18. Locate VOLUME CONTROL 100 OHM 10 WATT (4750-0049) and install into service switch bracket as shown in figure 4.
19. Locate TEST, SERVICE, VOLUME STICKER and place on the service switch bracket as shown in figure 4.

20. Locate KNOB 1/8" SHAFT (6010-0043) and install on shaft of volume control 100 ohm 10 watt as shown in figure 4.
21. Install the Service Switch Assembly using 2 ea #6 x 3/8 P/H PHIL TEK screws (0002-0000) in the cabinet at either of the following locations (see figure 5):
 - On top of the steel enclosure for the Cash Box, inside the coin door.
Note: The TEK screws have a drill point and will drill through the steel enclosure.
 - Inside to the left of the coin door, mounted to the wood cabinet.

Harness Installation

22. Locate the JAMMA HARNESS (JAM-0000) and install as shown in figure 5. Use the provided (6 ea) 4" TIE WRAP (9992-0000) to secure the harness.
23. Connect the harness to the POWER SUPPLY as follows: (see figure 6)
 - a. +5 volt source. (Pins 3, 4, C, D of Jamma Harness)
 - b. +12 volt source. (Pins 6, F of Jamma Harness)
 - c. GND source. (Pins B, 27, e, 28, f of JAMMA HARNESS)
24. Connect the harness to the COIN DOOR as follows: (see figure 7.)
 - a. Connect the wire to coin chute 2 acceptor microswitch COMMON terminal. (Pin T of Jamma)
 - b. Connect the wire to coin chute 1 acceptor microswitch COMMON terminal. (Pin 16 of Jamma)
 - c. Connect the wire to coin chute 1 and 2 acceptor microswitch NORMALLY OPEN terminal. (Pin A of JAMMA)
 - d. Also connect Pin A JAMMA to one side of each lamp on the coin door.
 - e. Connect +5 volts from the power supply to the other side of each lamp on the coin door.
25. Connect the harness to the COIN METER by using two WIRE NUTS (2112-0000). (see figure 8) **Note:** Some coin meters have an internal diode.

26. Connect the harness to the CONTROL PANEL as follows:
 - a. Route and connect the daisy chained wire to the terminal of the PLAYER PUSH BUTTONS and JOYSTICK as shown in figure 9.
 - b. Connect the control panel harness wires as follows: (figure 10)

	JAMMA PIN #
TO PLAYER 1 START	17
TO PLAYER 1 JOYSTICK UP	18
TO PLAYER 1 JOYSTICK DOWN	19
TO PLAYER 1 JOYSTICK LEFT	20
TO PLAYER 1 JOYSTICK RIGHT	21
TO PLAYER 1 ATTACK	22
TO PLAYER 1 JUMP	23
TO PLAYER 1 NINJA MAGIC	24
TO PLAYER 2 START	U

27. Connect the T.V. Monitor as shown in figure 11.
28. Connect the routed speaker wires to the speaker. Check the routing for security.
29. Connect the JAMMA HARNESS (JAM-0000) to the SERVICE SWITCH ASSY as follows: (See figure 4)
 - a. Connect the JAMMA Harness pin L and SPEAKER (-) terminal to the left outside pin of the Volume Control 100 ohm 10 watt Rheostat (4750-0049).
 - b. Connect the JAMMA Harness pin 10 to the right outside pin of the Volume Control 100 Ohm 10 watt Rheostat.
 - c. Connect the SPEAKER (+) terminal to the center pin of the Volume Control 100 Ohm 10 watt Rheostat.
 - d. Connect the JAMMA Harness pin 15 to one side of the "TEST" Momentary Push Button Switch (5090-5028).
 - e. Connect the JAMMA Harness pin f to the other side of the "TEST" Momentary Push Button Switch.
 - f. Connect the JAMMA Harness pin R to one side of the "SERVICE" Momentary Push Button Switch (5090-5028).
 - g. Connect the JAMMA Harness pin f to the other side of the "SERVICE" Momentary Push Button Switch.

**Cabinet 115 VAC
System Grounding**

30. Locate the GROUND lead (green) of the 115 volt input power Line (see figure 12). This must be connected to all components of the game system. This is a safety requirement for the players' protection. This AC GROUND must be of #18 AWG wire or larger. (see figure 12 for the proper routing of the wire)

Cabinet System Checkout

31. Apply power to cabinet system and check for the following voltages. If any voltage is incorrect, remove power and correct problem before proceeding any further.
 - a. +5 Volts on pins 3,4,C, and D of the 56 pin PCB connector.
 - b. +12 Volts on pins 6 and F of the 56 pin PCB connector.
 - c. No voltage present on any other pins of the 56 pin PCB connector.

Shadow Dancer Printed Circuit Board Installation

32. Check that the monitor has power. This can be accomplished by observing the glow of the filament inside the neck of the picture tube.
33. Check that the Marquee lamp has power.
34. Check that the system ON/OFF switch functions properly.

WARNING: PROCEED ONLY IF THE ABOVE CHECKS ARE CORRECT

35. Connect the Logic P.C.B. edge connector into the 56 pin connector on the JAMMA HARNESS. (NOTE: Proper orientation of each board is "Component Side Up").
36. See the SHADOW DANCER SWITCH SETTING SHEET on page 21 of this manual. Place this sheet on the inside of the game so that it is visible when the back door is removed or opened. This will allow the DIP SWITCH OPTIONS to be handy when service or changes in options are required.
37. Install the logic PCB inside the cabinet (see figure 5). Use (4 ea) #6 x 3/4 P/H PHIL "AB" SMS (0002-0001) to secure the PCB through its mounting feet.

NOTE: The proper orientation of the connector (see figure 13). If not connected properly, the system will not function and damage can occur to the PCB.

Logic Board and Complete System Checkout

38. Apply power to the system and observe that the logic PCB functions. If a video picture is not present proceed to "IN CASE OF DIFFICULTY" portion of this manual. When corrected, return to this point and continue.

39. Press the TEST BUTTON to enter the test menu. Individual tests can be entered by moving the Joystick. Press the test switch again to enter the test.
- **Memory test:**
Tests all main program Rom and Ram accessible by the main CPU.
 - **Input test:**
Tests all player inputs.
 - **Sound test:**
Tests all sounds. Move the Joystick UP or DOWN to select Sound category and move RIGHT or LEFT to select individual sounds. Press ATTACK to test.
 - **CRT test:**
Displays color bar and grid size so monitor adjustment can be made for color, focus, size, etc.
 - **Dip switch test:**
Shows current Dip Switch settings. (Dip Switches may be changed in this mode with power on.)
 - **Back-up RAM clear:**
Enables erasure of all bookkeeping information, high scores, etc.
 - **Exit:**
(Press test when arrow lines with this to exit to normal game mode.)
 - **Bookkeeping:**
Shows all coin credit in data and displays high/low scores, etc.
40. Set up game options as shown in figure 14.
- a. DIP SWITCH 1 on PCB sets up the number of coins per credit
 - b. DIP SWITCH 2 on PCB sets up the following:

1 Credit to Start	- Set to OFF	- 1 OFF
Advertise Sound	- Set to ON	- 2 ON
Game Difficulty	- Set to NORMAL	- 5, 6 OFF
41. Functionally test the game by:
- a. VERIFY that coin drops register proper credit/s and the COIN METER OPERATES.
 - b. VERIFY that the proper number of lives is given for each CREDIT.
 - c. VERIFY that the JOYSTICK MOVES the player left, right, and down.
 - d. VERIFY that each ATTACK BUTTON functions.
 - e. VERIFY that each JUMP BUTTON functions.
 - f. VERIFY that each NINJA MAGIC BUTTON functions.
42. Locate the Kit SERIAL NUMBER STICKER and FCC STICKER. Install these stickers on the rear of the game cabinet. (see figure 1)

CONVERSION IS COMPLETE

In Case of Difficulty

- Check A.C. line cord
 - Check line fuse
 - Check monitor brightness
 - Check power switch and/or interlock switch
 - Check all solder connections on line filter and transformer
 - Check for proper orientation of the 56 pin PCB connector
-
- Check all PCB to monitor connections
 - Check power supply voltage on PCB
-
- Check monitor brightness
 - Check all PCB to monitor connections
-
- Monitor needs degaussing
 - Check for proper wiring between PCB and monitor
 - Check monitor adjustment and adjust if necessary
-
- Check monitor ground is properly connected to monitor
 - Be certain sync inputs are properly connected to monitor
 - Check horizontal hold adjustment
-
- Check horizontal and/or vertical hold adjustments
 - Check for proper wiring of sync from PCB to monitor
-
- Check volume control potentiometer adjustment
 - Check for + 12 volts on edge connector of PCB
 - Check wiring from PCB to speaker
 - Check speaker for low resistance between the "+" and "-" tabs
-
- Check wiring to speaker for bad solder connections.
 - Check sound with another speaker
-
- Check ground connection to switch/es
 - Check wiring between PCB and switch/es for proper connection
 - Check switch/es with an ohmmeter to verify proper operation
-
- Check wiring between PCB and switches for proper orientation
 - Check wiring for shorts between switch inputs
-
- Check wiring to coin meter
 - Check that + 5 volts is on "+" side of meter
 - Verify a + 5 volt meter is used
-
- Verify that a meter with a diode is used
 - If no diode is built in meter a 1N4004 can be used across the meter.
Cathode to "+" side of meter and anode to "-" side of meter

ILLUSTRATIONS

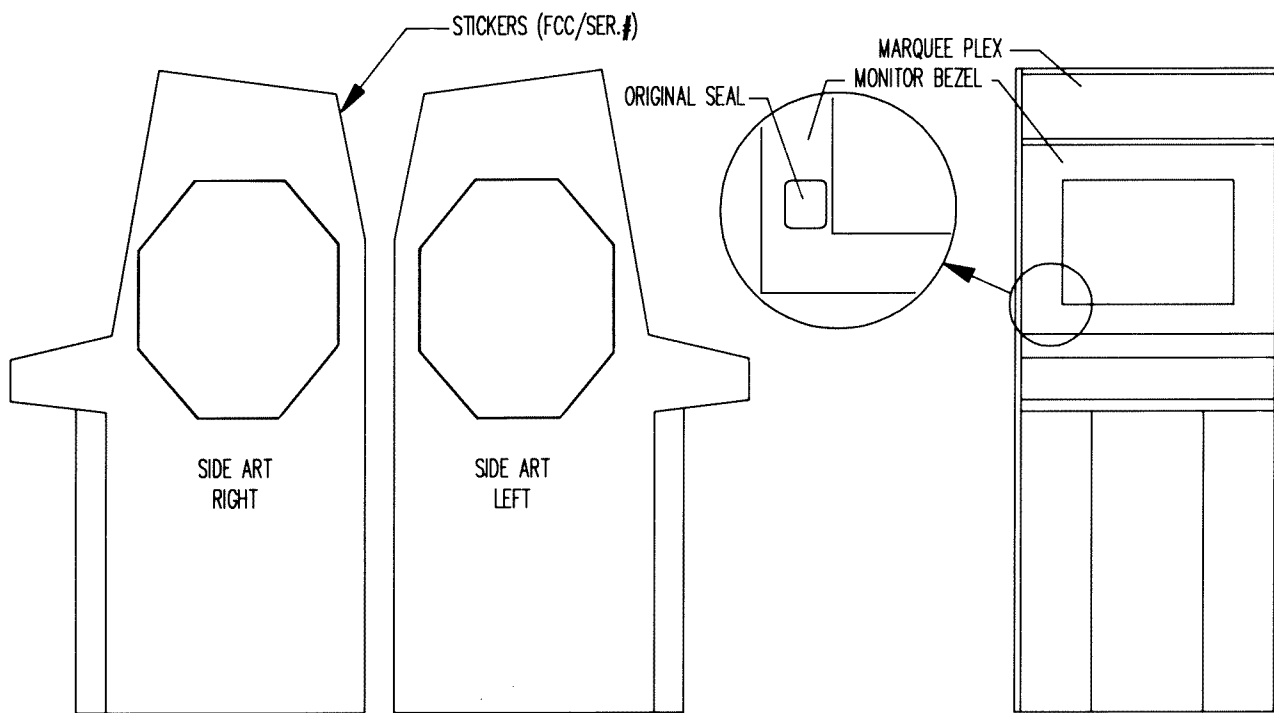
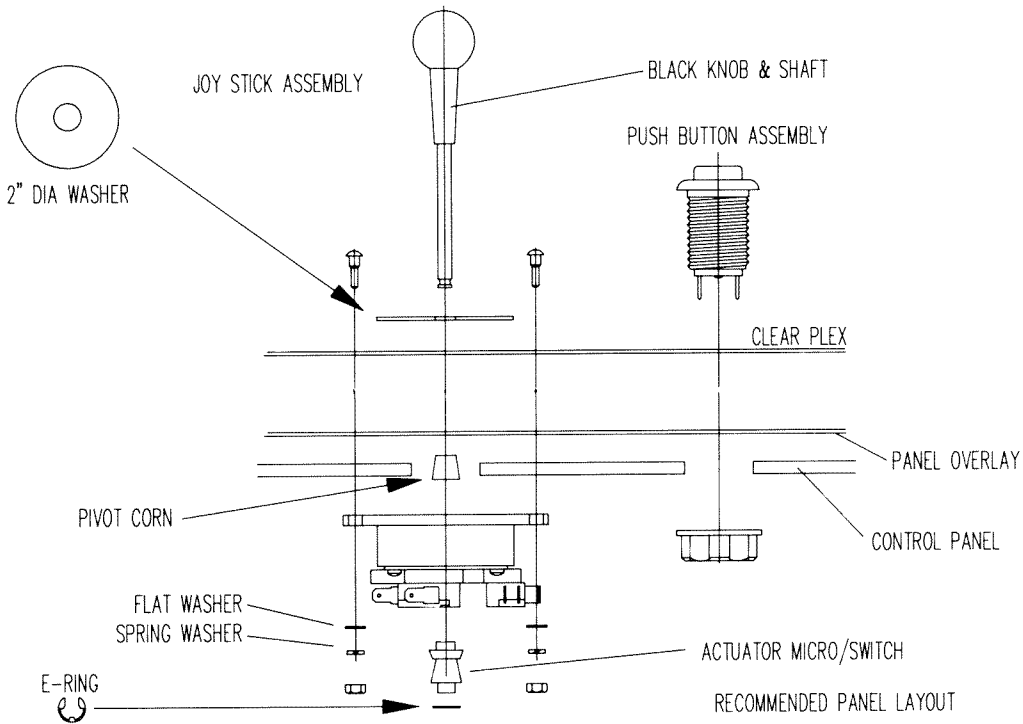
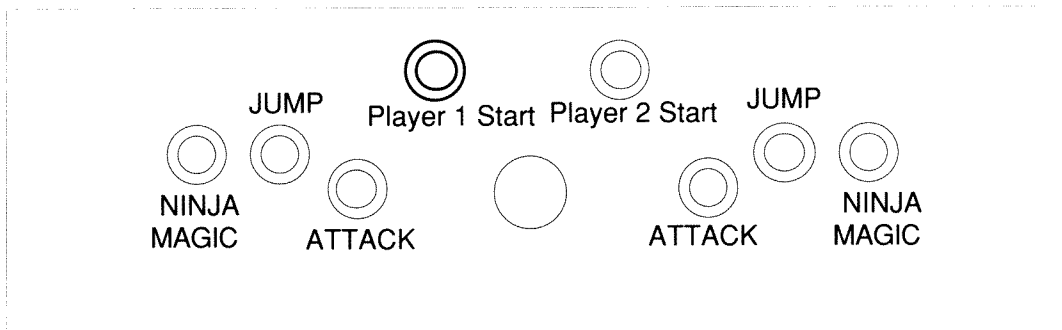

Figure 1



CONTROL PANEL TOP VIEW



SUGGESTED LAYOUT AND HOLE SIZES (TOP VIEW)

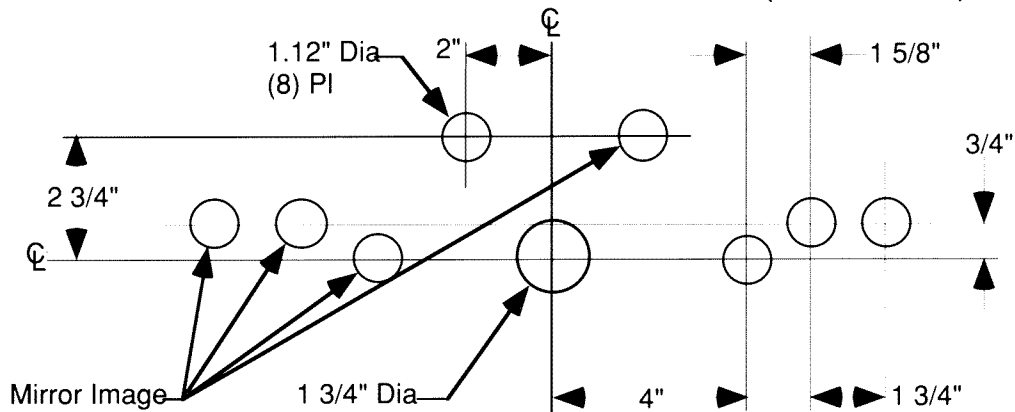

Figure 2

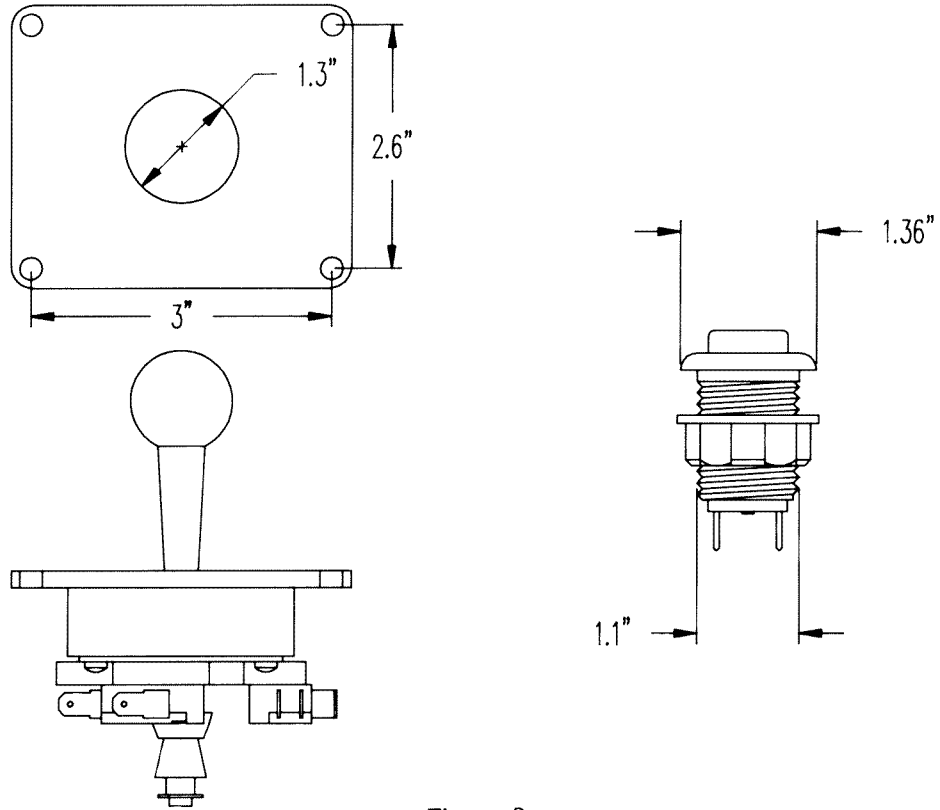

Figure 3

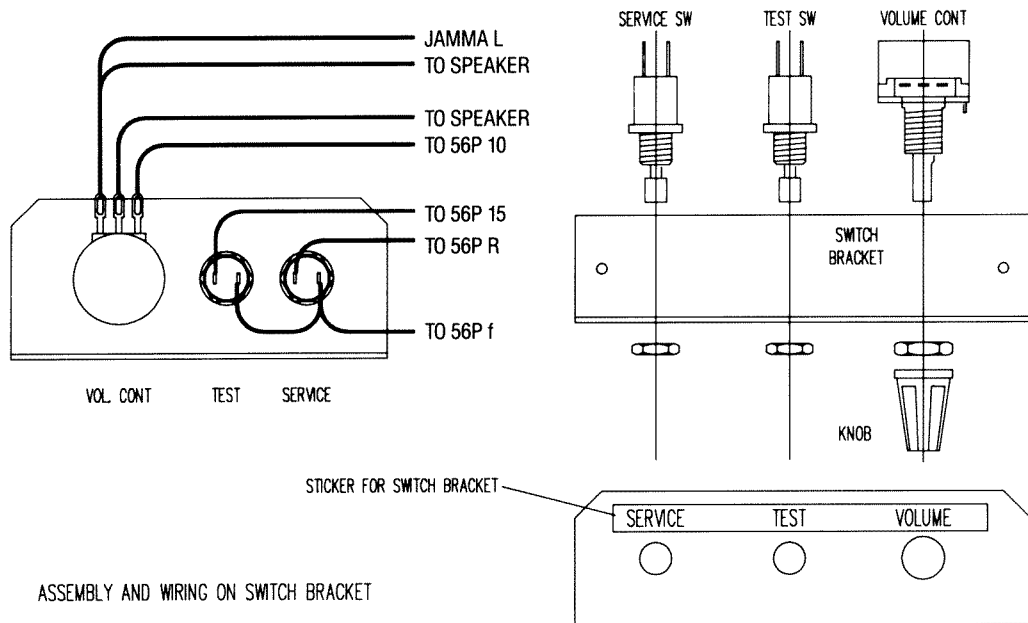
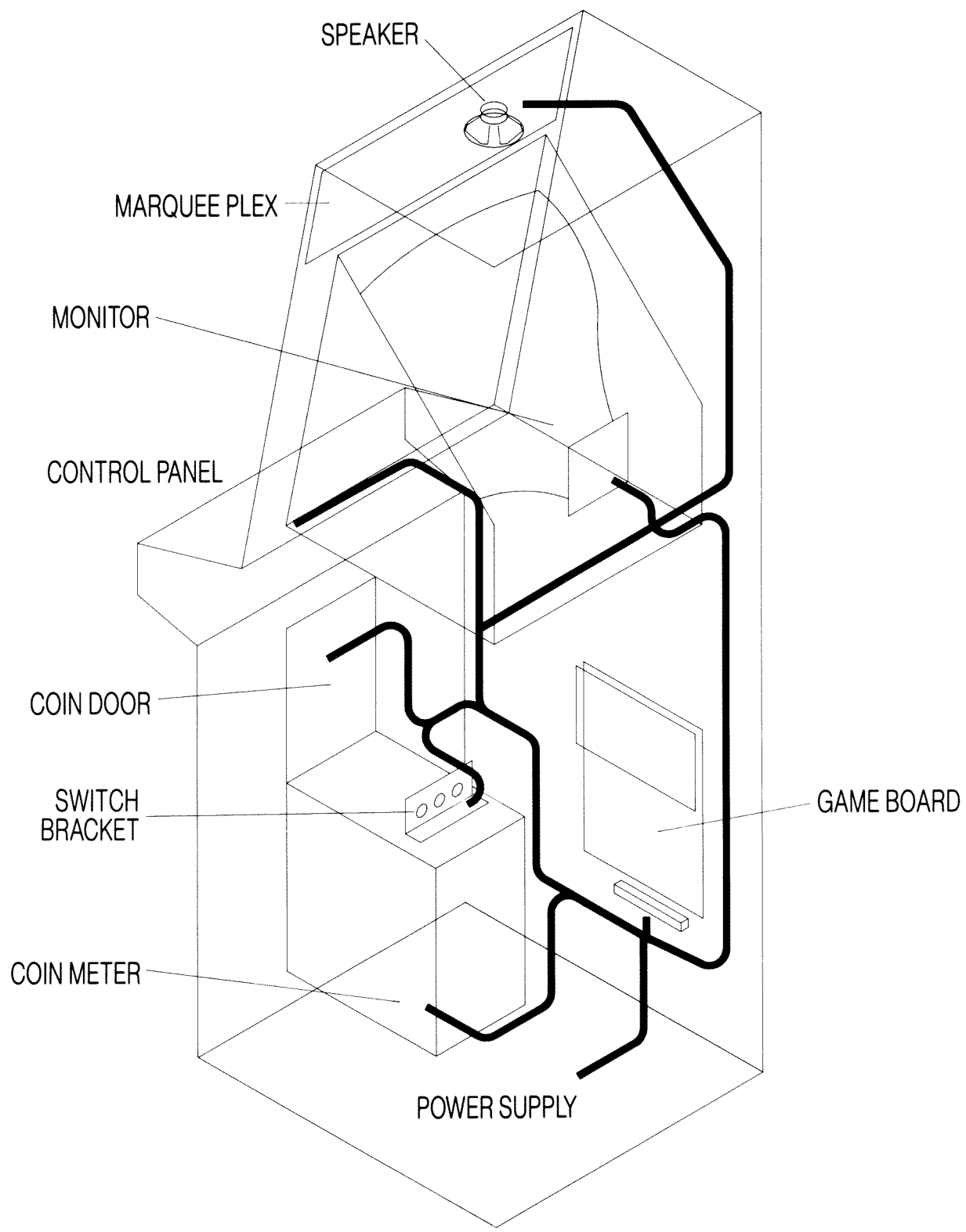

Figure 4



SUGGESTED HARNESS ROUTING

Figure 5

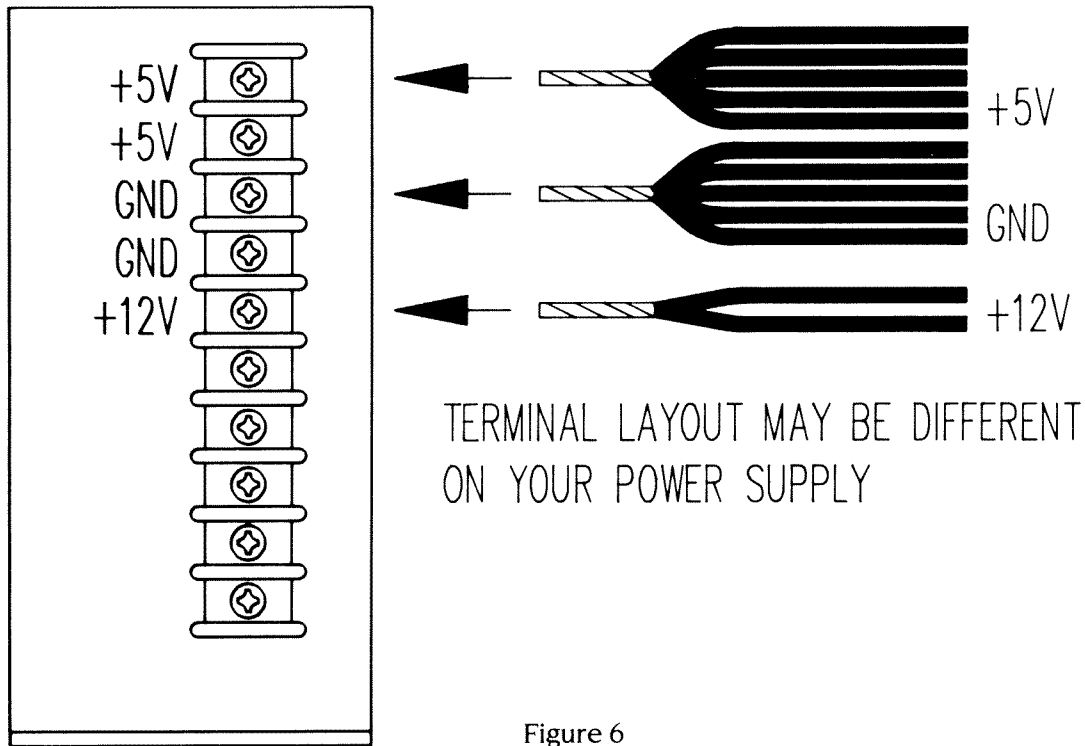

Figure 6

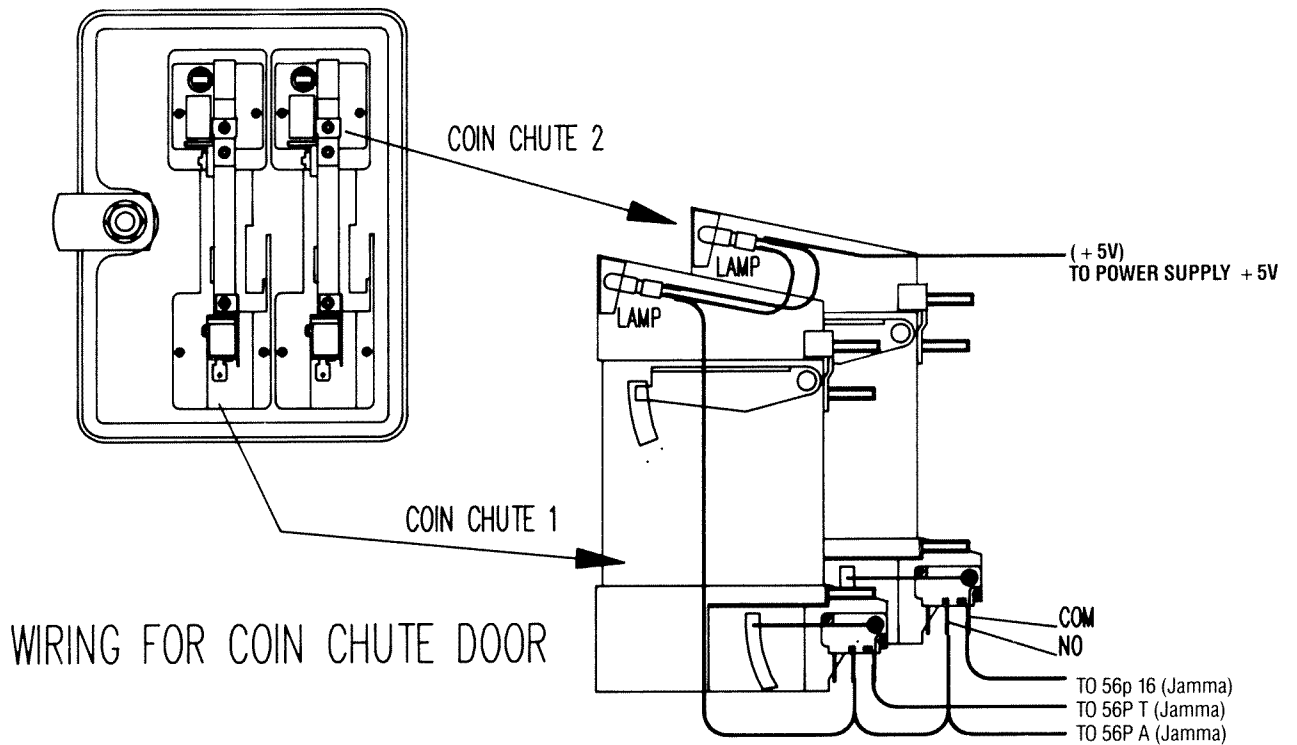

Figure 7

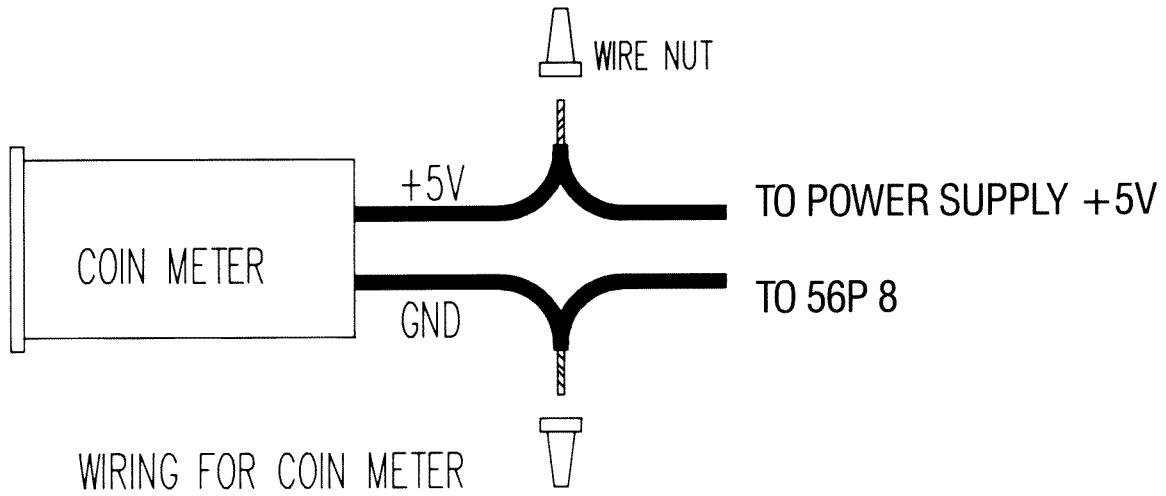

Figure 8

CONTROL PANEL REAR VIEW
GROUND ROUTING

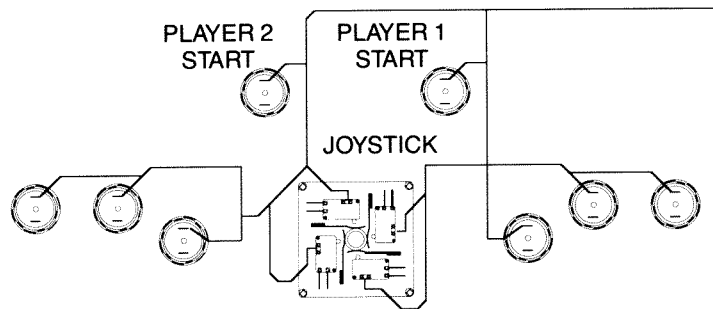

Figure 9

CONTROL PANEL REAR VIEW
SIGNAL ROUTING

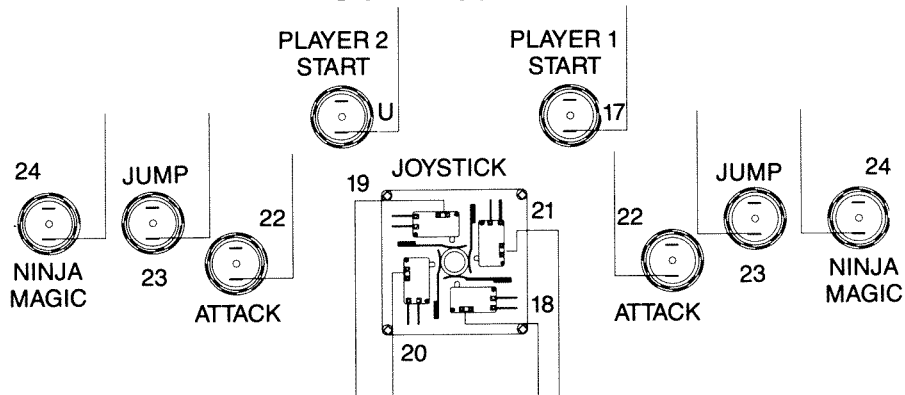

Figure 10

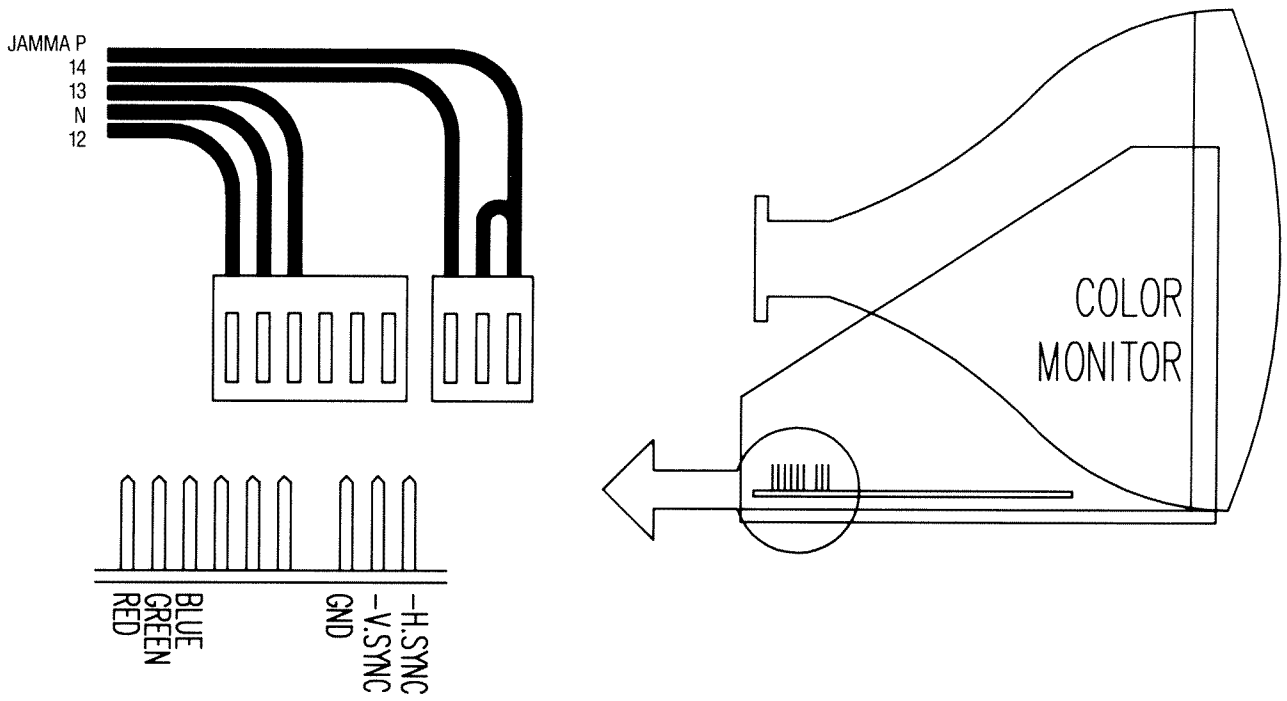

Figure 11

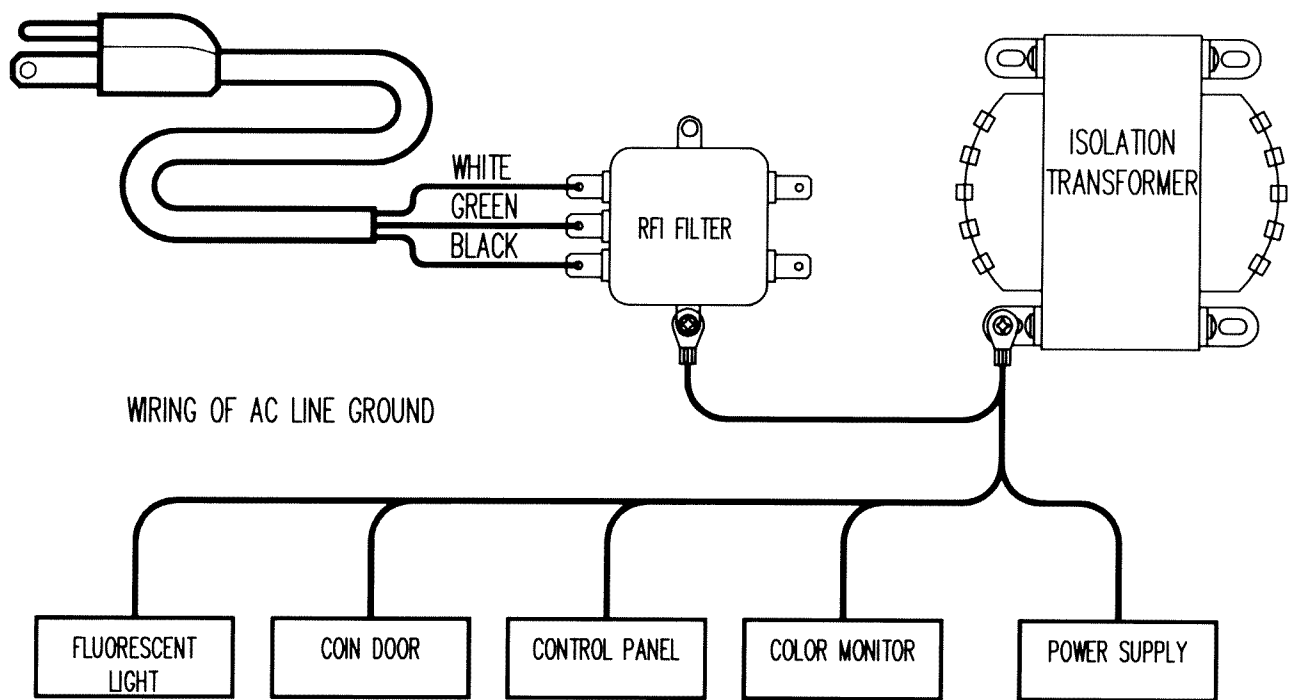

Figure 12

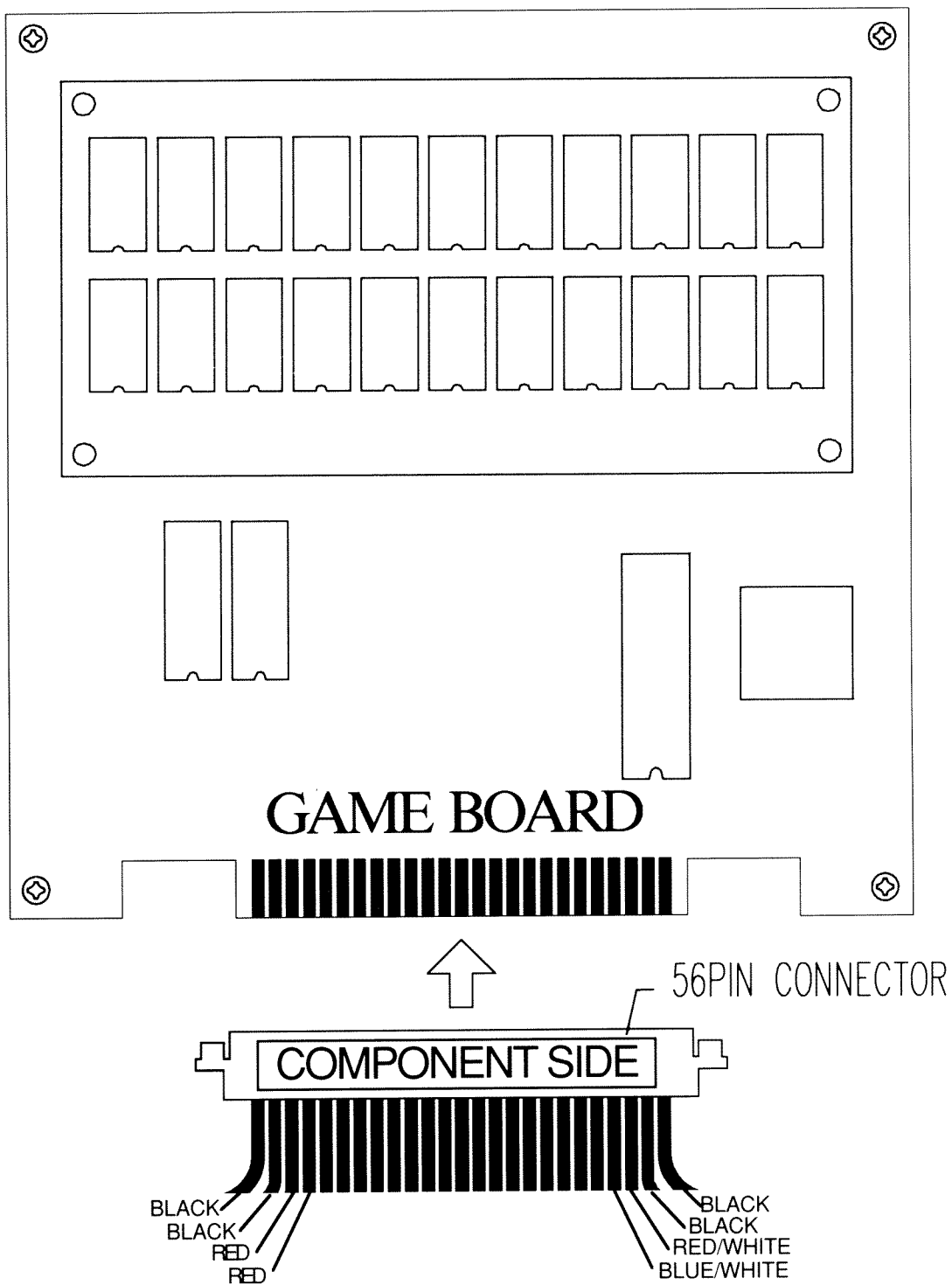

Figure 13

COIN/CREDIT OPTION SWITCH SETTING		DIP SW #1							
OPTION		1	2	3	4	5	6	7	8
1 COIN 1 CREDIT		OFF	OFF	OFF	OFF	OFF	OFF	OFF	OFF
1 COIN 2 CREDITS		ON	OFF	OFF	OFF	ON	OFF	OFF	OFF
1 COIN 3 CREDITS		OFF	ON	OFF	OFF	OFF	ON	OFF	OFF
1 COIN 4 CREDITS		ON	ON	OFF	OFF	ON	ON	OFF	OFF
1 COIN 5 CREDITS		OFF	OFF	ON	OFF	OFF	ON	OFF	OFF
1 COIN 6 CREDITS		ON	OFF	ON	OFF	ON	OFF	ON	OFF
2 COINS 1 CREDIT		OFF	ON	ON	OFF	OFF	ON	ON	OFF
3 COINS 1 CREDIT		ON	ON	ON	OFF	ON	ON	ON	OFF
4 COINS 1 CREDIT		OFF	OFF	OFF	ON	OFF	OFF	OFF	ON
2 COINS 2 CREDITS		ON	ON	OFF	ON	ON	ON	OFF	ON
4 COINS 2 CREDITS		OFF	ON	OFF	ON	OFF	ON	OFF	ON
5 COINS 3 CREDITS		ON	ON	ON	ON	ON	ON	ON	ON
6 COINS 4 CREDITS		ON	ON	ON	ON	ON	ON	ON	ON
1 COIN 1 CREDIT		OFF	OFF	ON	ON	OFF	OFF	ON	ON
2 COINS 2 CREDITS		ON	OFF	ON	ON	ON	OFF	ON	ON
3 COINS 3 CREDITS		ON	ON	ON	ON	ON	ON	ON	ON
4 COINS 4 CREDITS		ON	ON	ON	ON	ON	ON	ON	ON
5 COINS 6 CREDITS		ON	ON	ON	ON	ON	ON	ON	ON
1 COIN 1 CREDIT		OFF	ON	ON	ON	OFF	ON	ON	ON
2 COINS 3 CREDITS		ON	ON	ON	ON	ON	ON	ON	ON
FREE PLAY		ON	ON	ON	ON	ON	ON	ON	ON
		COIN SW #1				COIN SW #2			

MONITOR
 HORIZONTAL

GAME OPTION SETTINGS		DIP SW #2							
OPTIONS		1	2	3	4	5	6	7	8
START CREDIT	1 CREDIT 2 CREDITS	OFF ON							
ADVERTISE SOUND	OFF ON		OFF ON						
NUMBER OF PLAYER	3 4 5 2			OFF ON OFF ON	OFF OFF ON ON				
GAME DIFFICULTY	NORMAL EASY HARD HARDEST					OFF ON OFF ON	OFF OFF ON ON		
TIMER	3:00 3:30 2:40 2:20							OFF ON OFF ON	OFF OFF ON ON

PIN ASSIGNMENT-JAMMA PIN-OUT			
COMPONENT SIDE			SOLDER SIDE
GND	1	A	GND
GND	2	B	GND
+5V	3	C	+5V
+5V	4	D	+5V
	5	E	
+12V	6	F	+12V
KEY	7	H	KEY
COIN METER 1	8	J	COIN METER 2
	9	K	
SPEAKER (+)	10	L	SPEAKER (-)
	11	M	
VIDEO RED	12	N	VIDEO GREEN
VIDEO BLUE	13	P	VIDEO SYNC
VIDEO GND	14	R	SERVICE
TEST	15	S	
COIN 1	16	T	COIN 2
1P START	17	U	2P START
1P UP	18	V	
1P DOWN	19	W	
1P LEFT	20	X	
1P RIGHT	21	Y	
1P ATTACK	22	Z	
1P JUMP	23	a	
1P NINJA MAGIC	24	b	
	25	c	
	26	d	
GND	27	e	GND
GND	28	f	GND

56P P:3.96 mm

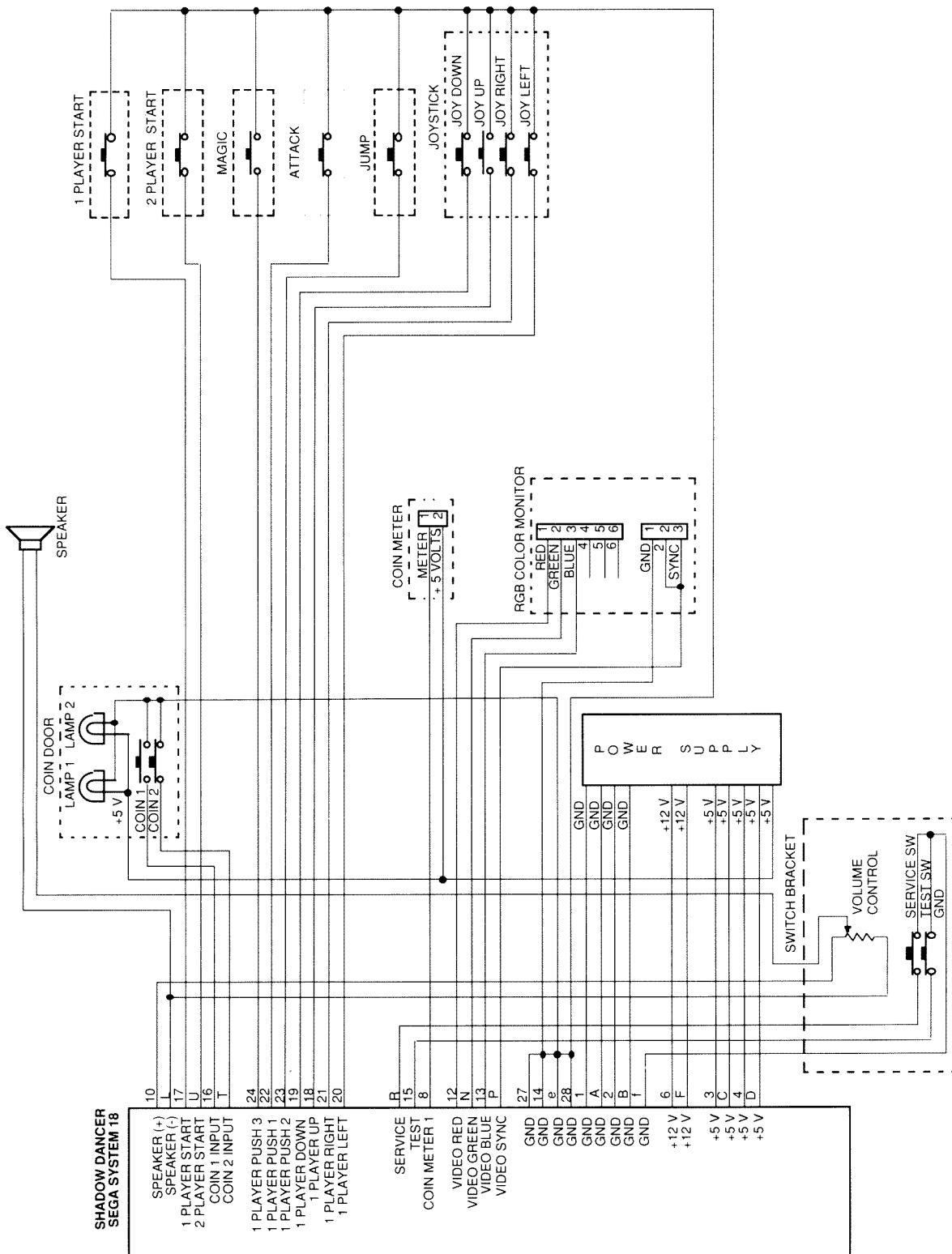

Schematic Design

SEGA Enterprises, Inc. (U.S.A.)
2149 Paragon Drive
San Jose, California 95131
Phone Number (408) 435-0201
FAX Number (408) 435-0294