

T.M.

ROC 'N ROPE CONVERSION KIT INSTRUCTION MANUAL

Kosuka Co., Ltd. Licensed by Konami © 1983

Distributed by: Interlogic, Inc. 9806 W. Farragut Ave. Rosemont, IL 60018
Tel.: (312) 671-0306 Telex: 270359 INTRLOGIC ROSM



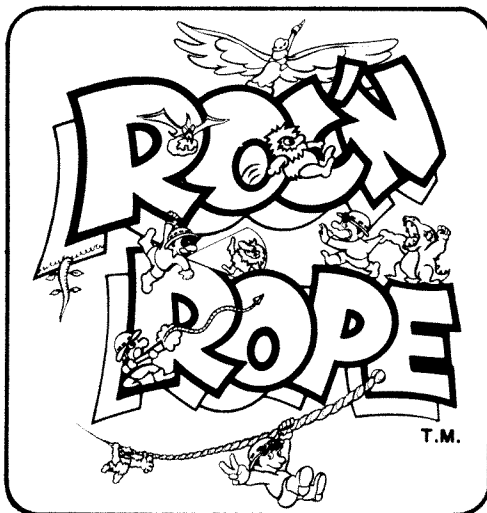

CONVERSION KIT CONTENTS:

- 1 - Main Printed Circuit Board**
- 1 - P. C. Board Cage (FCC Required)**
- 1 - Connecting Wiring Harness**
- 1 - Marquee (Header) Overlay**
- 1 Set - Side Panel Graphics (Left and Right)**
- 1 - Control Panel Overlay**
- 1 - Button Assembly**
- 1 Set - Control Button Decals**
(1 Player, 2 Player, Flash, Rope)
- 1 - Player Instruction Decal**
- 1 - Copyright Seal (For Marquee)**
- 1 - Technical Instruction Manual**
- 1 - Registration Card**

Note: Replacement Accessories Available Through Your Distributor...OR



9806 W. Farragut Ave. / Rosemont, IL 60018
Tel: (312) 671-0305 / Telex: 270359 INTRLOGIC ROSM

ROC 'N ROPE: To The Technician

INTRODUCTION

This instruction manual has been specifically designed for your use. It will provide you with adequate information to convert your old game as simply as possible.

Contained herein are schematic diagrams for working with our printed circuit board. For better

understanding, a Main Block Diagram and a Sound Board Block Diagram are supplied.

Everything that you will need to construct your new game is provided in this kit, as listed on the preceding contents page.

QUESTIONS AND ANSWERS

#1 Q. Will it be necessary to change the power supply?

A. If present power supply cannot handle the following current* parameters, it will be necessary.

* +5V 5.0A
-5V 0.5A
+12V 1.0A or 2.0A

#2 Q. What machines can be converted?

A. Any game with color raster monitor can be converted with this kit.

#3 Q. Is it necessary to Replace/Change the present Joystick?

A. Yes. This kit includes a standard "WICO" 8-way Joystick for maximum player maneuverability.

#4 Q. How much wiring is involved?

A. Relatively very little. It is recommended that you **DO NOT CUT** the existing connectors after removal of the old logic board. By using the old schematics and wiring, you can save time by soldering the new connecting wires to the old ones. These old wires show exactly where to connect the new wires.

SELF-TEST

A. Self test on Logic Board automatically during "POWER ON".

B. If the board is "OK", the game will start.

C. When "V-RAM" is in error, it will display "V-RAM OUT" on the screen.

D. When "WORK RAM" is in error it will display as follows:

ADDRESS Error between 5000H and 57FFFH W-RAM 1 OUT
ADDRESS Error between 5800H and 5FFFH W-RAM 2 OUT

E. When "OBJ-RAM" is in error it will show as follows:

ADDRESS Error between 4000H and 43FFFH OBJ 1 OUT
ADDRESS Error between 4400H and 47FFFH OBJ 2 OUT

A FEW SUGGESTIONS

As far as non-technical tools are concerned, you will need a sharp x-acto knife to make accurate incisions in your control panel overlay. The easiest way to do this is; First, clean and dry the control panel - thoroughly. Second, **slowly** apply the overlay - inch by inch. Once it is in place, by using the x-acto knife, cut around the button and joystick placements. This will give you a professional finish.

Old stick-on side graphics can be removed by use of a hairdryer or hot air device. New graphics, (side panel decals and marquee overlay), should be applied to a clean formica, plexiglass (glass) or painted surface. For best cosmetic results, make sure that **all surfaces** are clean and dry before applying any decals.

**For Assistance Or Technical Support--
Contact Your Distributor or call:
INTERLOGIC at (312) 671-0305.**

USER INFORMATION
WARNING
F. C. C. REGULATION COMPLIANCE

THE P.C. BOARD CAGE SUPPLIED WITH THIS CONVERSION KIT MUST BE UTILIZED AND TERMINATED TO GROUND AT THE TIME OF INSTALLATION.

THIS IS TO AVOID RADIO FREQUENCY RADIATION AND COMPLY WITH THE LIMITS FOR A CLASS "A" COMPUTING DEVICE PURSUANT TO SUB-PART "J" OF PART 15 OF F.C.C. RULES, WHICH ARE DESIGNED TO PROVIDE REASONABLE PROTECTION AGAINST SUCH INTERFERENCE WHEN OPERATED IN A COMMERCIAL ENVIRONMENT.

OPERATION OF THIS EQUIPMENT IN A RESIDENTIAL AREA IS LIKELY TO CAUSE INTERFERENCE - IN WHICH CASE, THE USER AT HIS OWN EXPENSE, WILL BE REQUIRED TO TAKE WHATEVER MEASURES MAY BE REQUIRED TO CORRECT THE INTERFERENCE.

ROC 'N ROPE: Dip Switch Settings

A. DIP 1 SWITCH SETTING

SW1	SW2	SW3	SW4	SW5	SW6	SW7	SW8	COIN	PLAY
COIN 1 SW SETTING		COIN 2 SW SETTING							
OFF	OFF	OFF	OFF	OFF	OFF	OFF	OFF	1	1
ON	OFF			ON	OFF			1	2
OFF	ON			OFF	ON			1	3
ON	ON			ON	ON			1	4
OFF	OFF	ON	OFF	OFF	OFF	ON	OFF	1	5
ON	OFF			ON	ON			1	6
OFF	ON			OFF	ON			1	7
ON	ON			ON	OFF			2	1
OFF	OFF	OFF	ON	OFF	ON	OFF	ON	2	3
ON	OFF			ON	ON			2	5
OFF	ON			OFF	OFF			3	1
ON	ON			ON	ON			3	2
OFF	OFF	ON	ON	OFF	ON	ON	ON	3	4
ON	OFF			ON				4	1
OFF	ON			OFF				4	3
ON	ON			ON					Freeplay SW1-4

C. DIP 3 SWITCH SETTING

C-1. How to set for Initial Bonus Player

SW	3	2	1	BONUS PLAYER
	OFF	OFF	OFF	NOT USED
0	OFF	OFF	ON	20,000
	OFF	ON	OFF	30,000
	OFF	ON	ON	40,000
	ON	OFF	OFF	50,000
	ON	OFF	ON	60,000
	ON	ON	OFF	70,000
	ON	ON	ON	80,000

C-2. How to set for Bonus Players to be awarded regularly.

SW	6	5	4	ONE BONUS PLAYER PER EVERY BONUS POINT
	OFF	OFF	OFF	NOT USED
	OFF	OFF	ON	NOT USED
	OFF	ON	OFF	NOT USED
	OFF	ON	ON	40,000
	ON	OFF	OFF	50,000
0	ON	OFF	ON	60,000
	ON	ON	OFF	70,000
	ON	ON	ON	80,000

C-3. Switch for above 1 only or 1 + 2.

SW	7	SELECTION
	OFF	1 ONLY
0	ON	1 + 2

C-4. Other Switch Settings

SW	8	
0	OFF	NOT USED
	ON	

B. DIP 2 SWITCH SETTING

B-1. The number of players

SW	2	1	NUMBER
0	OFF	OFF	3
	OFF	ON	4
	ON	ON	5
	ON	ON	255

B-2. Switch for change of Table or Upright.

SW	3	TYPE	
	OFF	TABLE	Using I/O for 1 or 2 player
	ON	UP RIGHT	Using I/O for 1 player only

B-3. Difficulty of Game

SW	7	6	5	4	DIFFICULTY
	OFF	OFF	OFF	OFF	1 (EASY)
			OFF	ON	2
			ON	OFF	3
			ON	ON	4
0	OFF	ON	OFF	OFF	5
			OFF	ON	6
			ON	OFF	7
			ON	ON	8
	ON	OFF	OFF	OFF	9
			OFF	ON	10
			ON	OFF	11
			ON	ON	12
	ON	ON	OFF	OFF	13
			OFF	ON	14
			ON	OFF	15
			ON	ON	15 (DIFFICULT)

B-4. Music in Attract Mode.

SW	8	MUSIC IN ATTRACT MODE
	OFF	OFF
0	ON	ON

NOTE:

“0” SHOWS NORMAL SETTING. THE LEVEL OF DIFFICULTY OF THIS GAME WAS SET AS IT IS BY KONAMI, ON THE BASIS OF MEETING THE AVERAGE PLAYER'S SKILL.

THEREFORE, THE LEVEL SHOULD REMAIN AS IT IS. IF THERE SHOULD BE A NECESSITY TO ALTER IT, IT SHOULD BE DONE WITH CONSIDERATION.

ROC 'N ROPE: Block Diagram - Sound Board

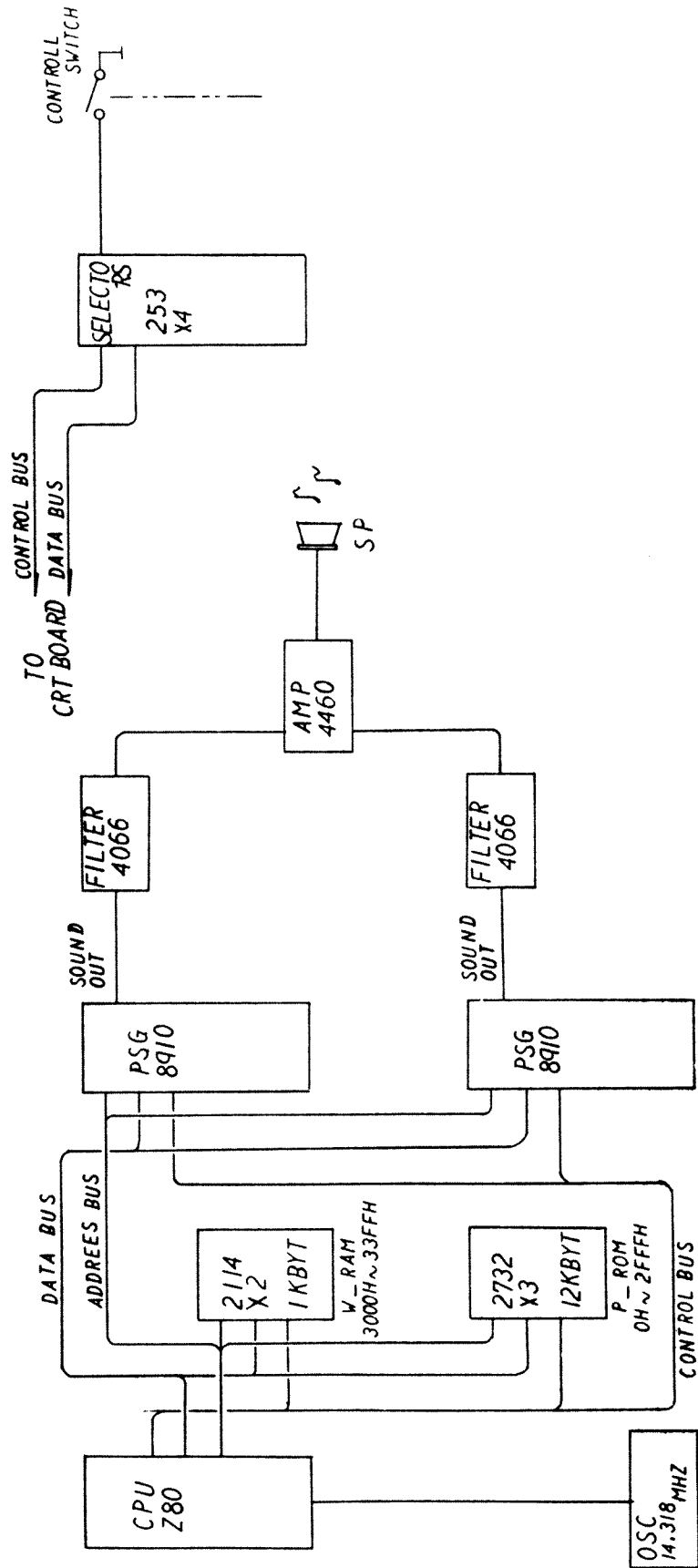

ROC 'N ROPE: Block Diagram - Main Board

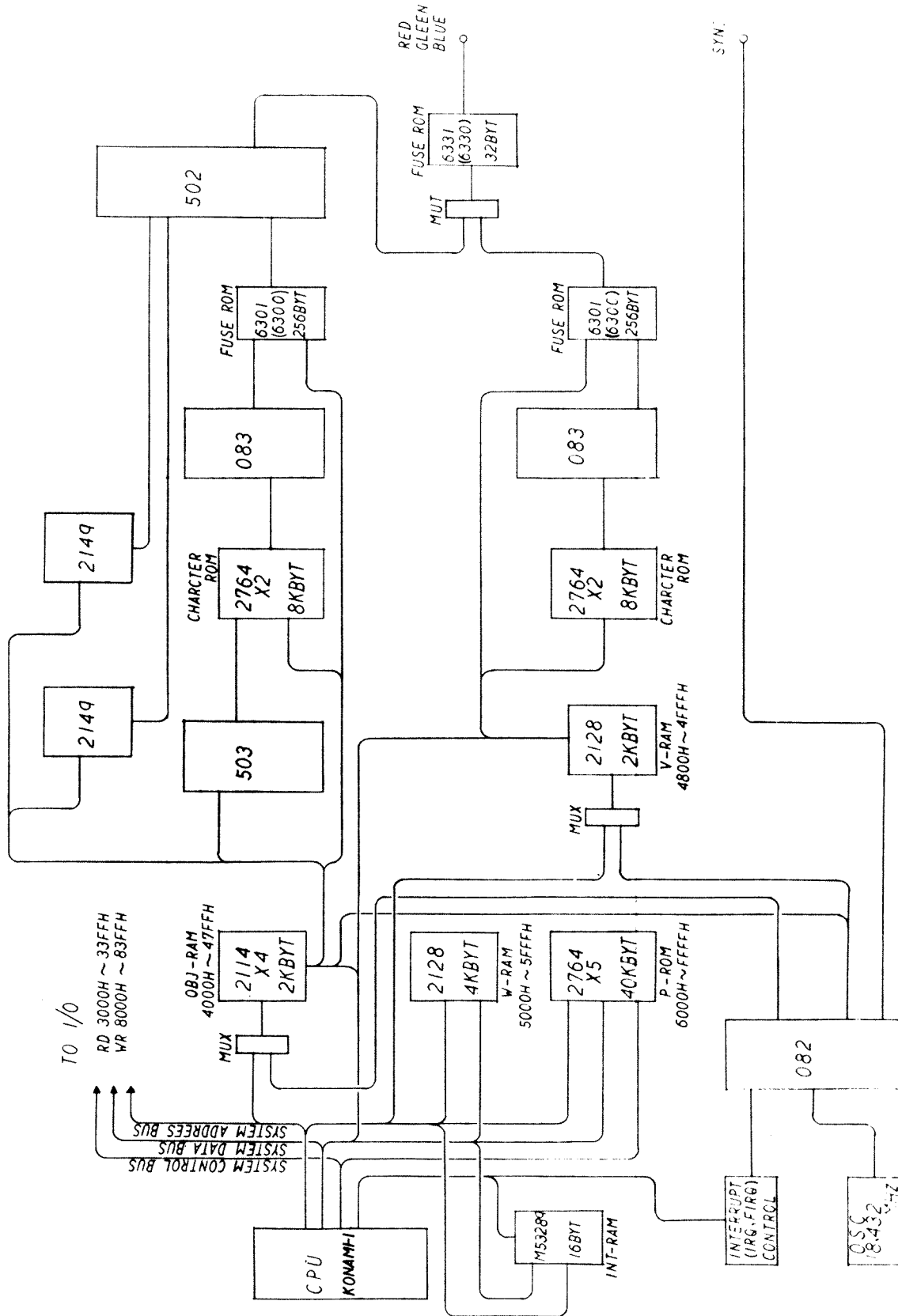

ROC 'N ROPE: I C Parts Layout Chart

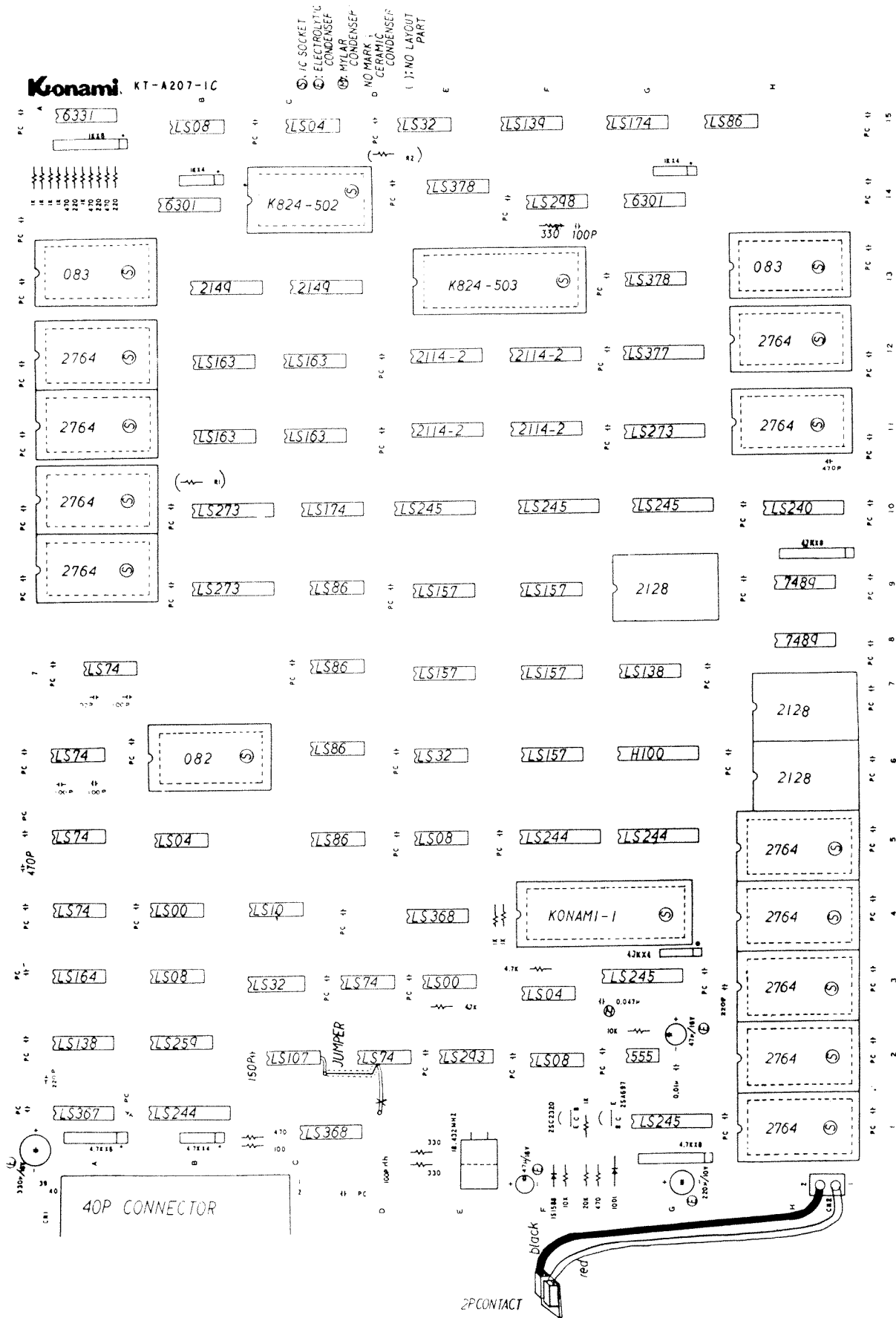

ROC 'N ROPE: Number of ROM and Disposition

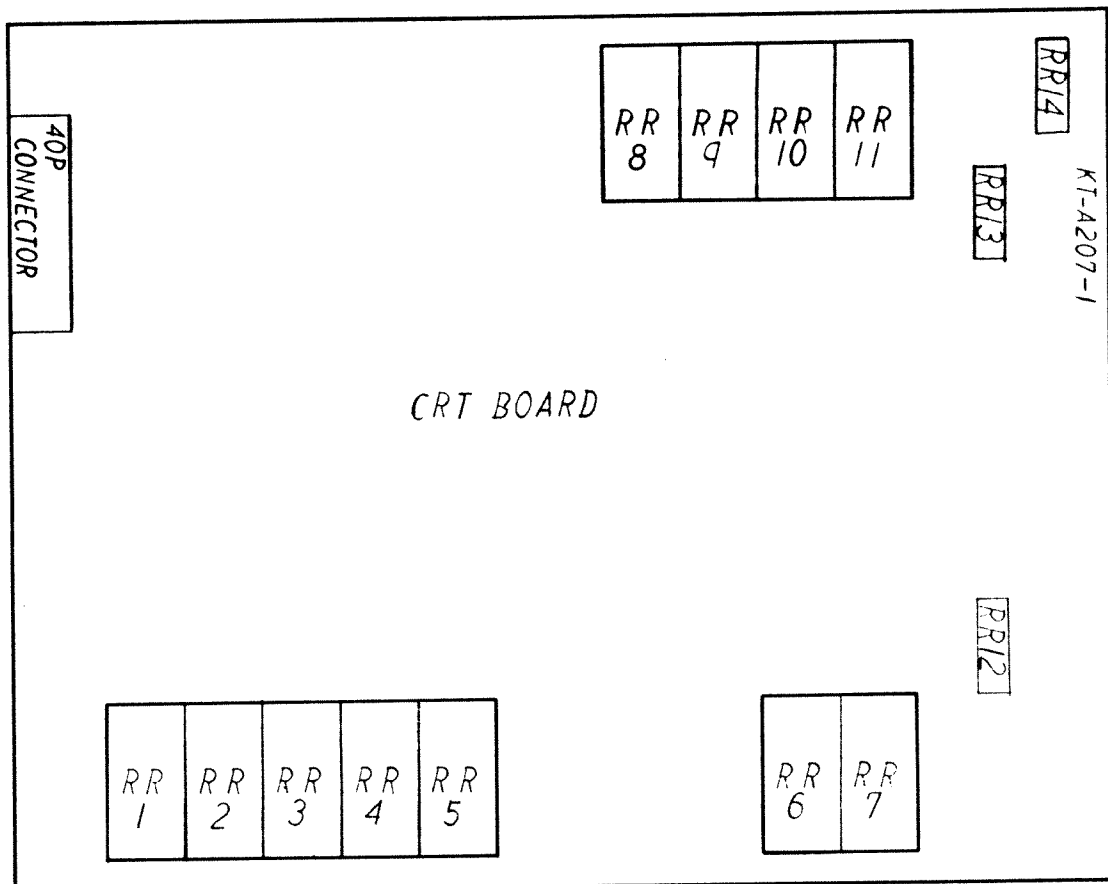
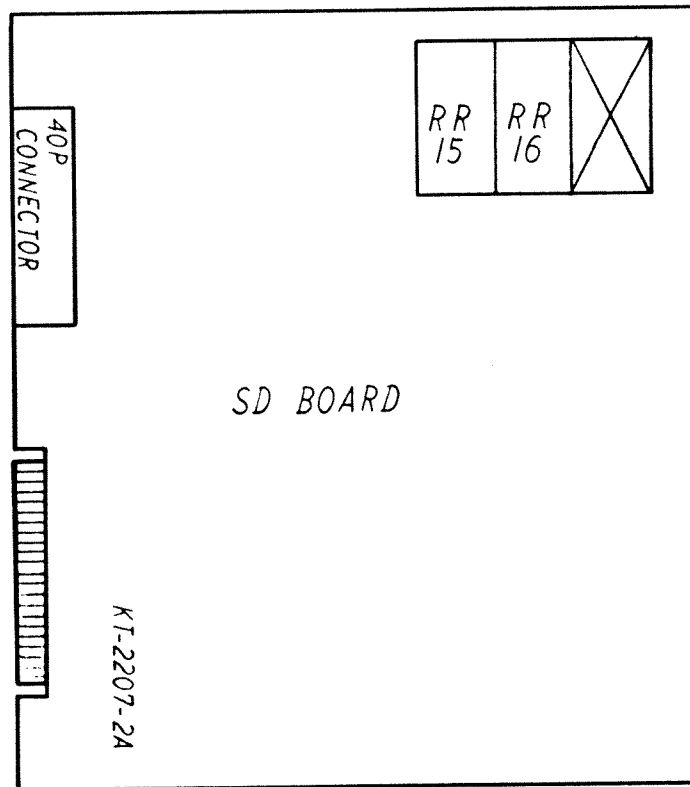

ROC 'N ROPE: General Wiring Diagram - Table Type

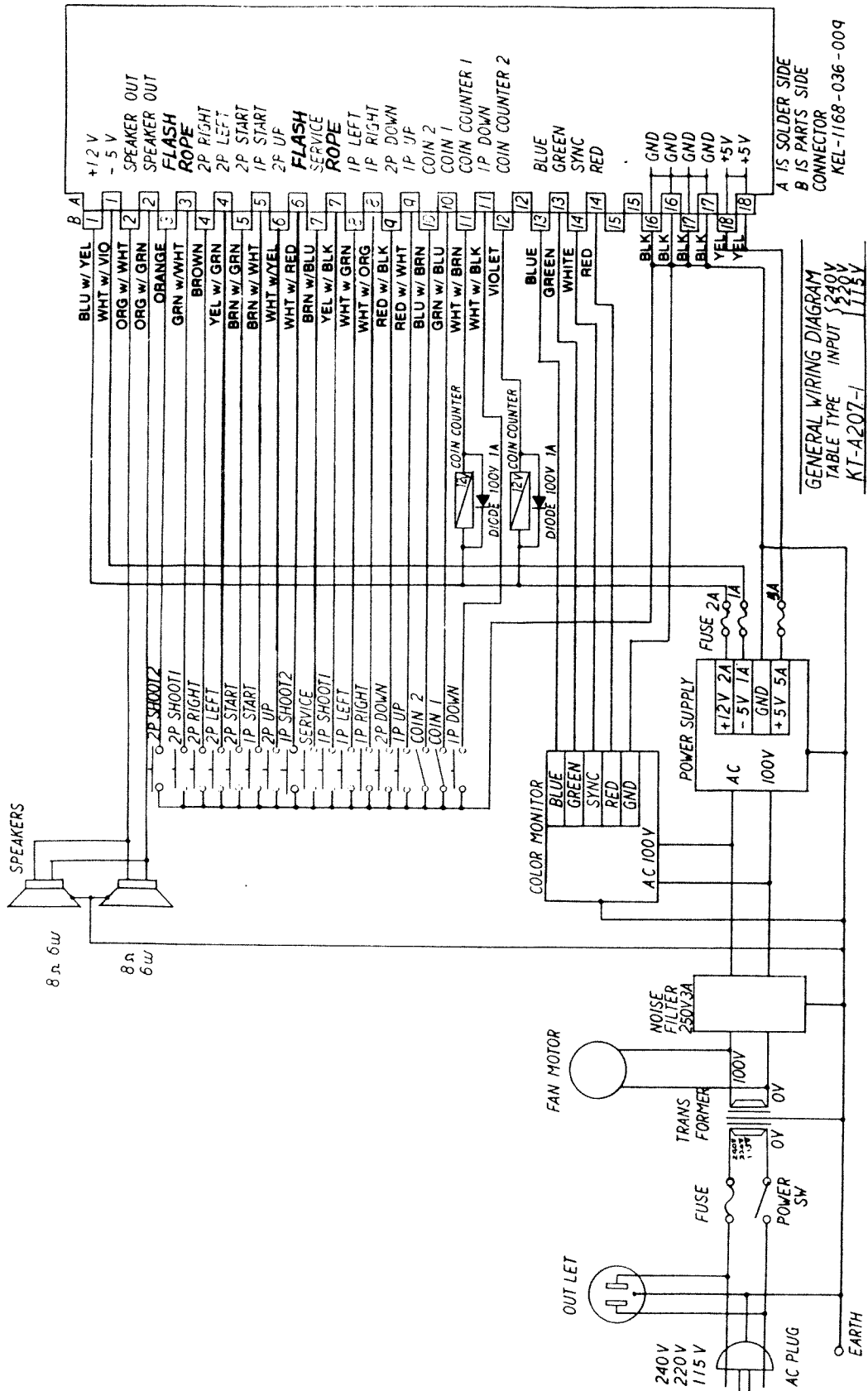

ROC 'N ROPE: General Wiring Diagram - Upright

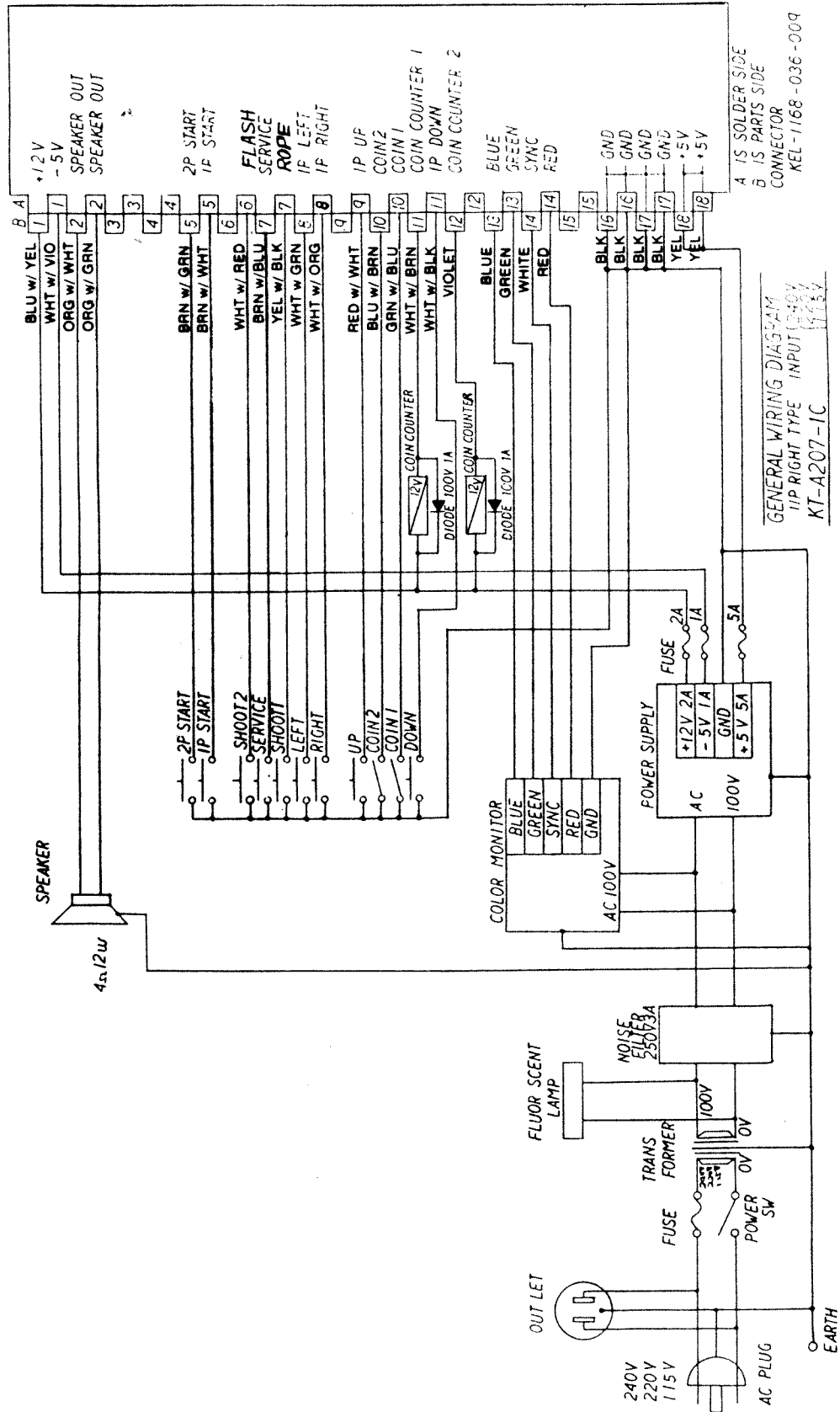

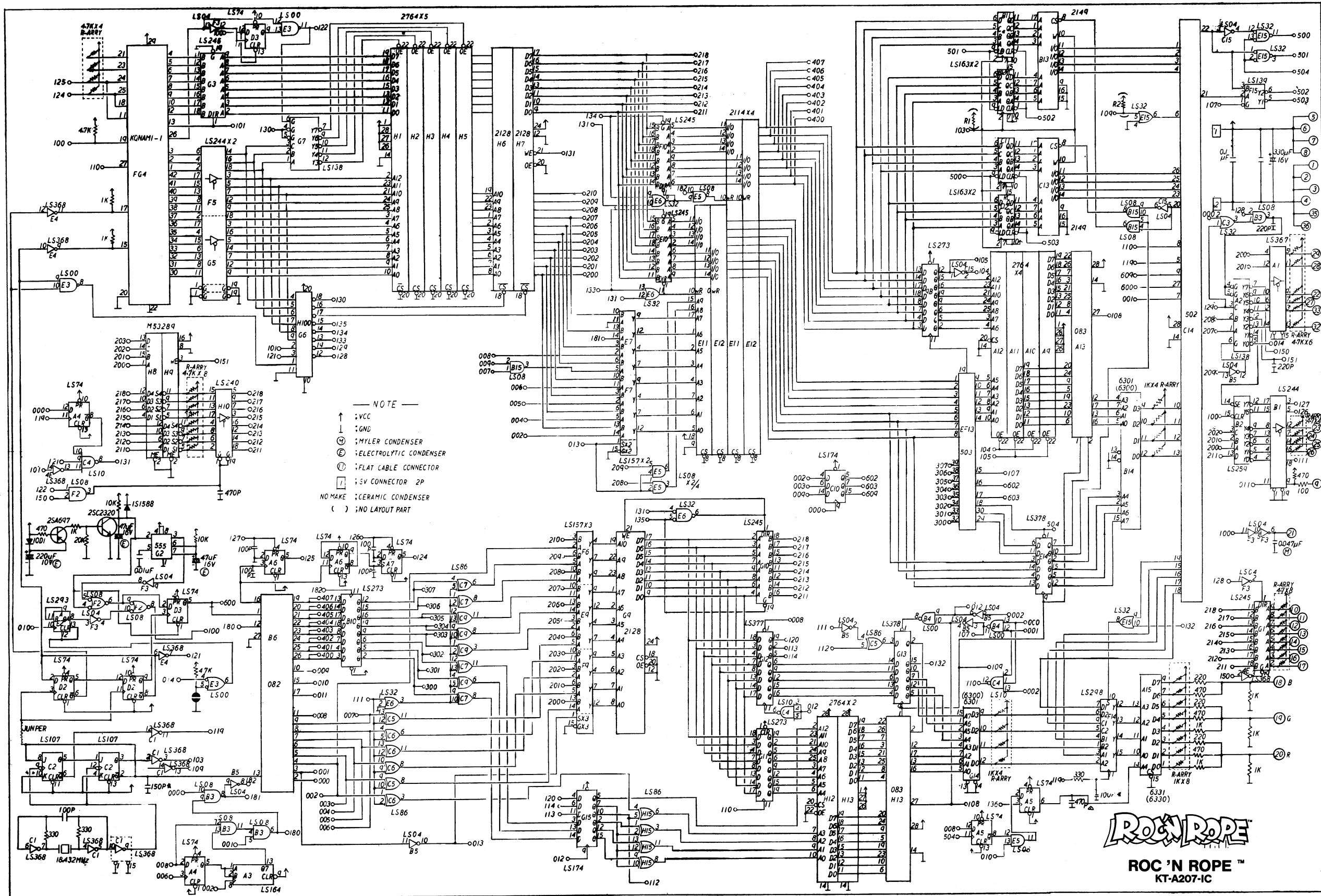

NOTE

- ↑ :VCC
- ↓ :GND
- ⊕ :MYLER CONDENSER
- ⊖ :ELECTROLYTIC CONDENSER
- Ⓛ :FLAT CABLE CONNECTOR
- Ⓜ :SV CONNECTOR 2P
- NO MAKE : CERAMIC CONDENSER
- () : NO LAYOUT PART



ROC 'N ROPE™
KT-A207-IC

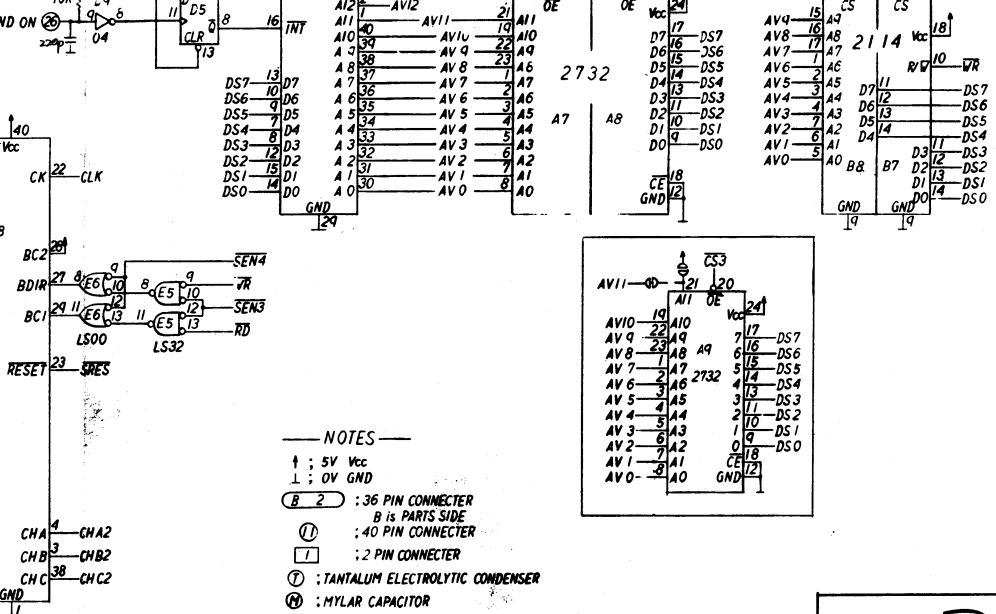
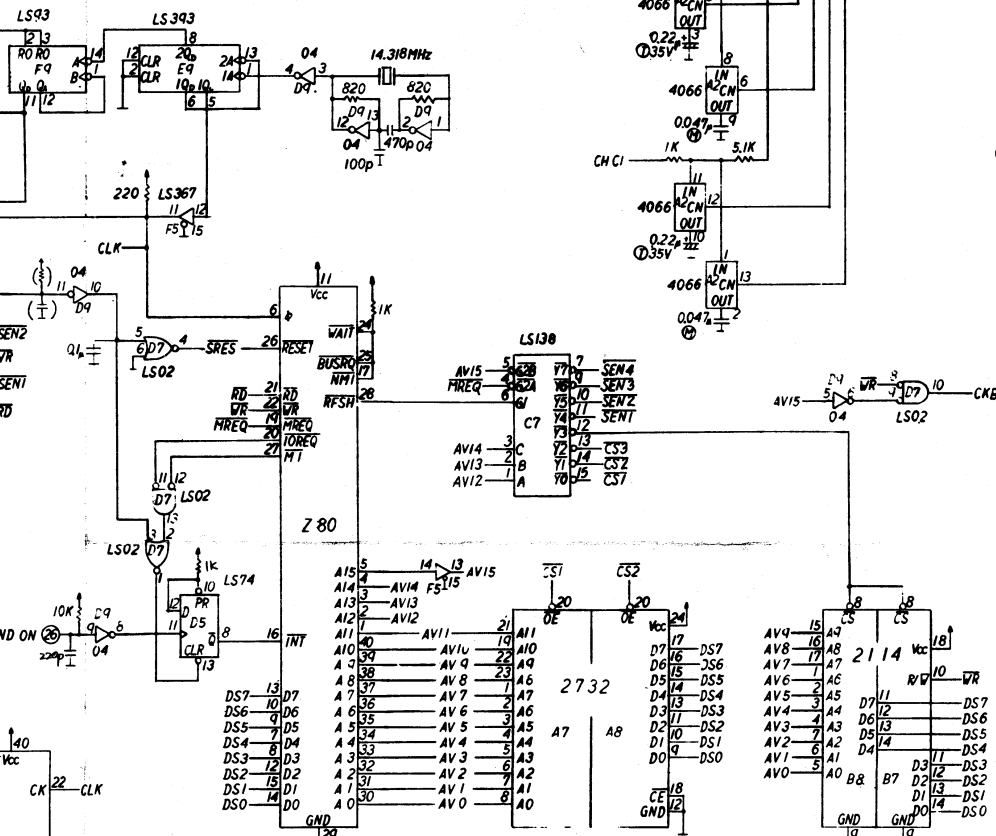
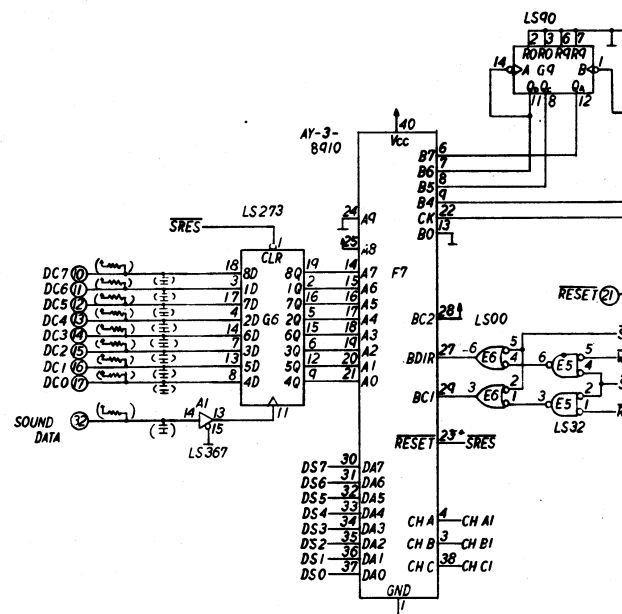
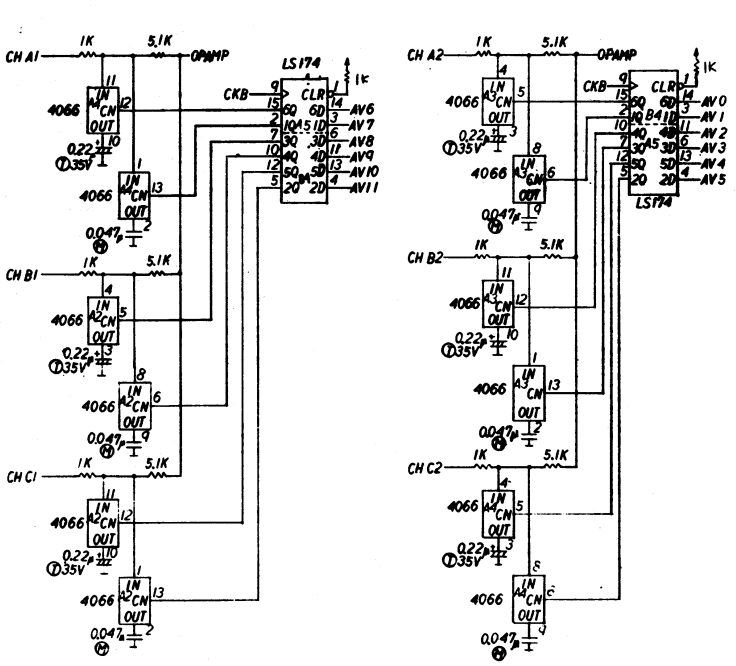
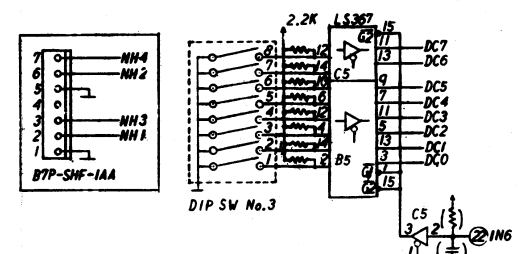
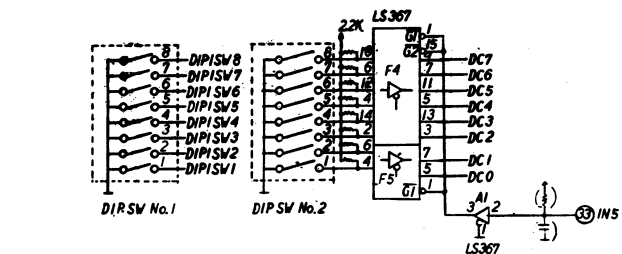
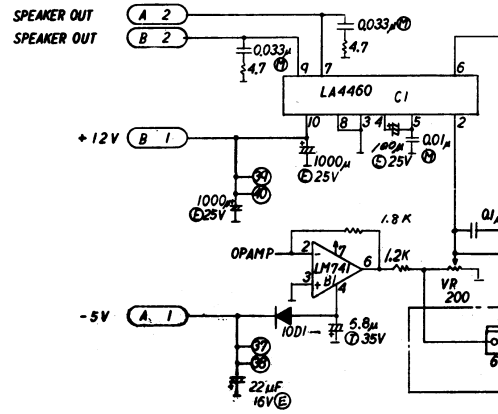
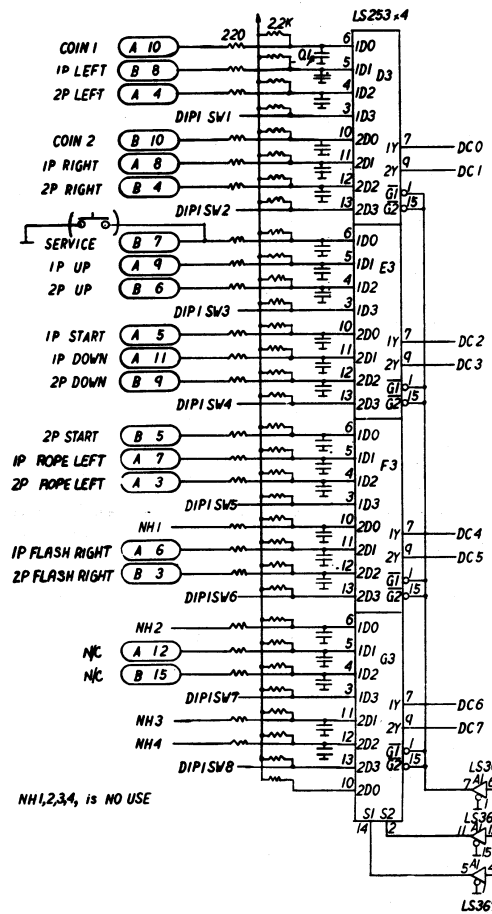
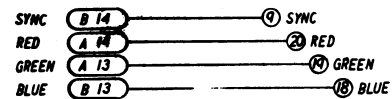
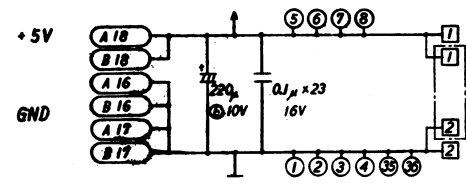

- NOTES
- ⊕ : 5V Vcc
 - ⊖ : 0V GND
 - (B 2) : 36 PIN CONNECTOR
B is PARTS SIDE
 - (1) : 40 PIN CONNECTOR
 - (I) : 2 PIN CONNECTOR
 - (T) : TANTALUM ELECTROLYTIC CONDENSER
 - (E) : MYLAR CAPACITOR
 - (C) : ELECTROLYTIC CONDENSER
 - NO MARK : CERAMIC CONDENSER
 - () : NO LAYOUT PARTS

