

SEGA®

HANG-ON

OWNER'S MANUAL

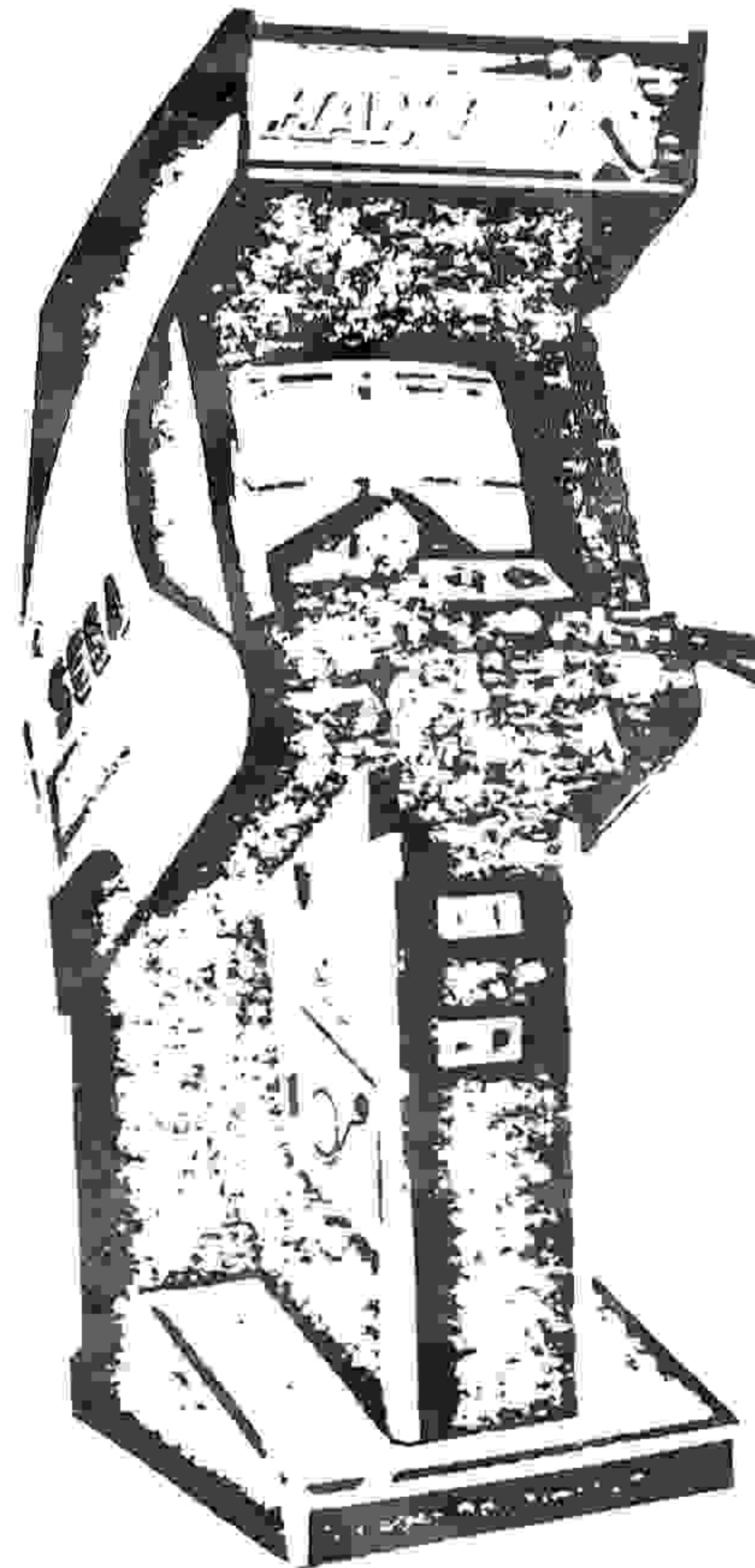

SEGA ENTERPRISES, LTD.

TABLE OF CONTENTS

INTRODUCTION OF THE OWNER'S MANUAL	1
1. HANDLING PRECAUTIONS	1
2. PREVENTION OF COUNTERFEITING AND CONVERSION	2
3. PRECAUTIONS CONCERNING THE PLACE OF INSTALLATION ...	3
4. EXTERIOR VIEW OF GAME ①	4
EXTERIOR VIEW OF GAME ②	5
5. ADJUSTMENT OF THE SERVICE SWITCH	6
6. DIP SWITCH SETTING	7
7. SETTING THE DIFFICULTY LEVEL FOR THE "UPRIGHT" TYPE	8
8. HANDLE'S CENTERING ADJUSTMENT	9
9. ADJUSTING THE ACCELERATOR/BRAKE	10
10. EPROM LOCATION	11 · 12
11. SELF-TESTING	13~19
12. REMOVING THE HANDLE COVER	20
13. REMOVING THE HANDLE UNIT	21
14. REMOVING THE WINDOW MASK	22
15. REPLACING THE ACCELERATOR/BRAKE VOLUME CONTROLS ...	23
16. REPLACING THE ACCELERATOR/BRAKE WIRES	24
17. PARTS LIST	25~39
18. SCHEMATIC DIAGRAM	40

SPECIFICATIONS

INSTALLATION SPACE	: 24.8 in. (63 cm) × 38.6 in. (98 cm)
HEIGHT	: 72.8 in. (185 cm)
POWER	: 185 W

NOTE

- o Descriptions herein contained may be subject to improvement changes without notice.

INTRODUCTION OF THE OWNER'S MANUAL

SEGA ENTERPRISES, LTD., supported by its high electronic technology of LSIS, microprocessors, etc. and a wealth of experience, has for more than 30 years been supplying various innovative and popular game machines to the world market. This OWNER'S manual is intended to provide detailed comments together with all the necessary information covering the operation in general of electronic assemblies, electromechanicals, servicing control, spare parts, etc. as regards the HANG·ON, a new SEGA product. The manual is intended for those who have knowledge of electricity and technical expertise especially in ICs, CRTs, microprocessors, etc. Carefully read so as to acquire sufficient knowledge before working on the machine. Should there be a malfunction, non-technical personnel should under no circumstance touch the interior system.

1. HANDLING PRECAUTIONS

When installing or inspecting, be very careful of the following points and pay attention to ensure that the player can enjoy the game safely.

- o Be sure to turn the power off before working on the machine.
- o To insert or pull out the plug quickly is dangerous.
- o It is necessary to make sure that the power cord or the grounding wire is not exposed on the road, etc. in a manner so as to be dangerous. Make sure that grounding connections are made safely at the position where so specified.
- o Do not use any fuse that does not meet the specified rating.
- o Make complete connections for the IC board and other connectors. Insufficient insertion is very dangerous.

Also, for the IC board circuit inspections, only the logic tone is allowed. The use of a tester is not permitted so be careful in this regard. After confirming that there are no irregularities, turn the power ON.

2. PREVENTION OF COUNTERFEITING AND CONVERSION

LABELLING

To prevent counterfeits and conversions, the following labels are put on all the SEGA products. When handling such goods, be sure to confirm the labels. They are used to prevent illegal acts such as the unauthorized copying of the products and the printed circuit boards thereof or carrying on business by manufacturing similar merchandise or by converting, selling or using such products or printed circuit boards.

ORIGINAL SEAL

The following seal is put on the machines manufactured by SEGA.



LICENCE SEAL

The following seal is put on the kits, such as the printed circuit boards, of SEGA products.

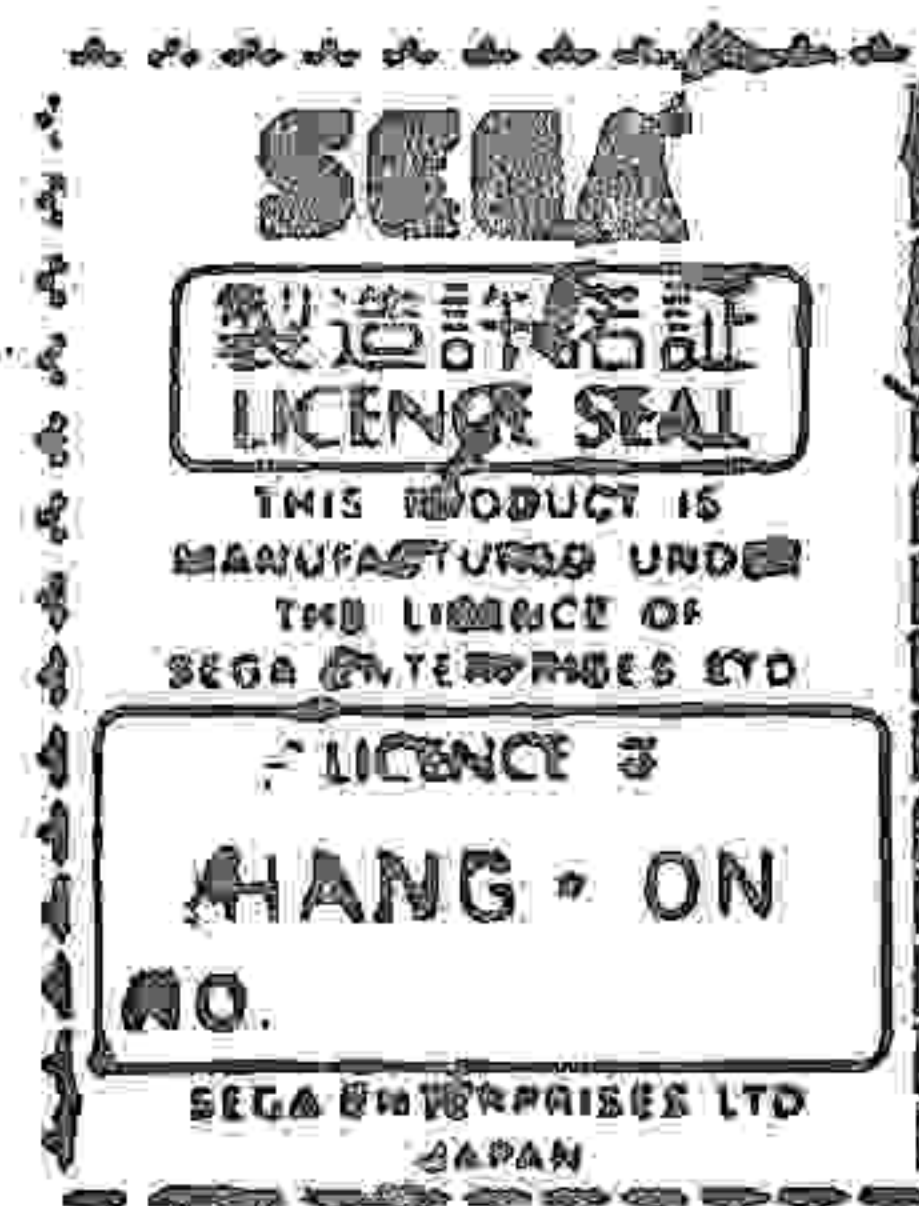

COPYRIGHT NOTICE

This SEGA product has the copyright notice as follows:

© SEGA 1985

This signifies that this work was disclosed in 1985 and is the property of SEGA ENTERPRISES, LTD.

3. PRECAUTIONS CONCERNING THE PLACE OF INSTALLATION

The HANG-ON is an indoor game machine. Absolutely do not install it outside. Even indoors, avoid installing in places mentioned below so as to ensure proper usage:

- o Places subject to rain or water leakage, or condensation due to humidity.
- o In the proximity of an indoor swimming pool and/or shower.
- o Places subject to direct sunlight.
- o Places subject to heat sources from heating units, etc., or hot air.
- o Vicinity of highly inflammable/volatile chemicals or hazardous matter.
- o Sloped surfaces.
- o Vicinity of anti-disaster facilities such as fire exits and fire extinguishers.
- o Places subject to any type of violent impact.
- o Dusty places.

4. EXTERIOR VIEW OF GAME ①

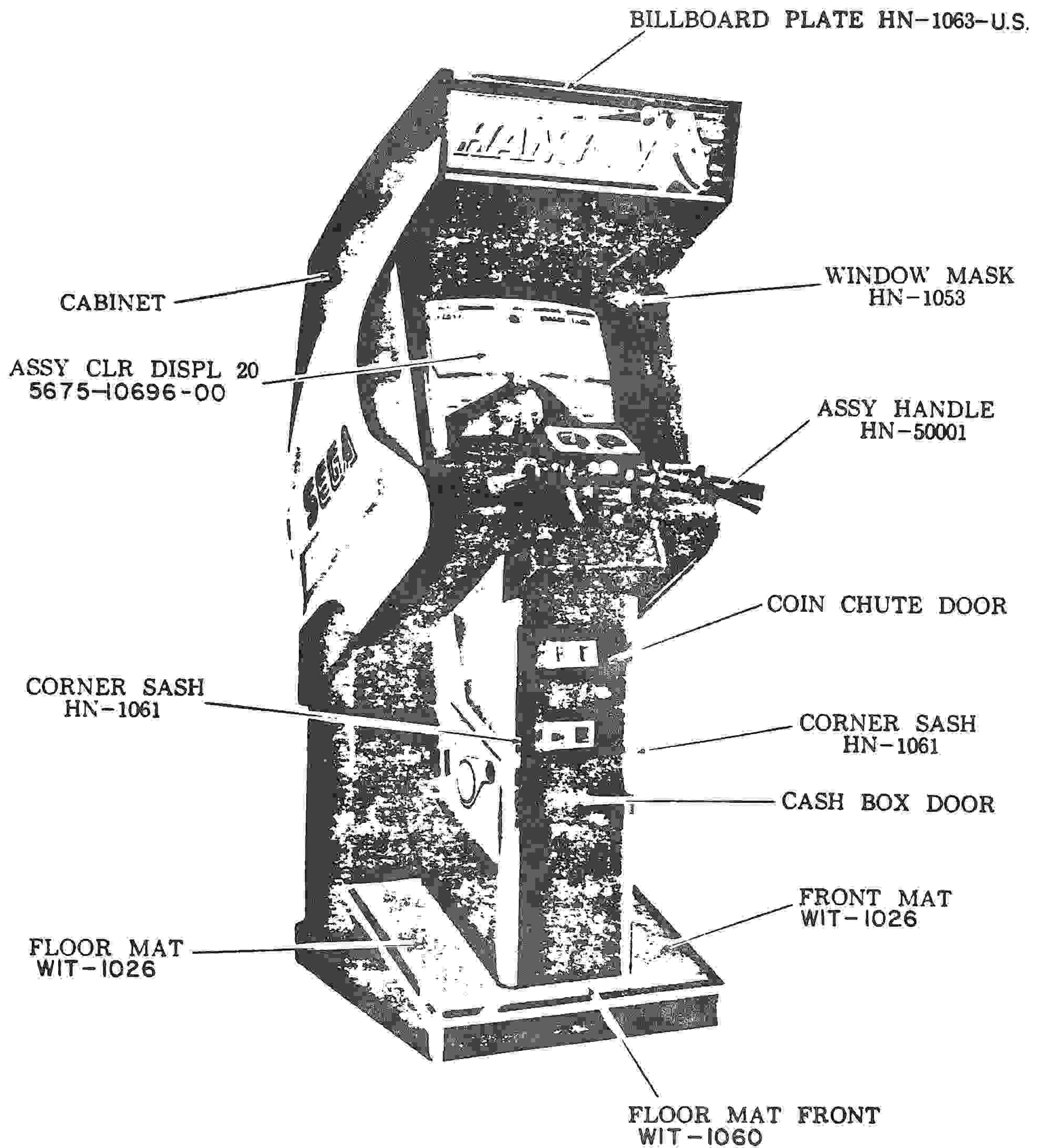

4. EXTERIOR VIEW OF GAME ②

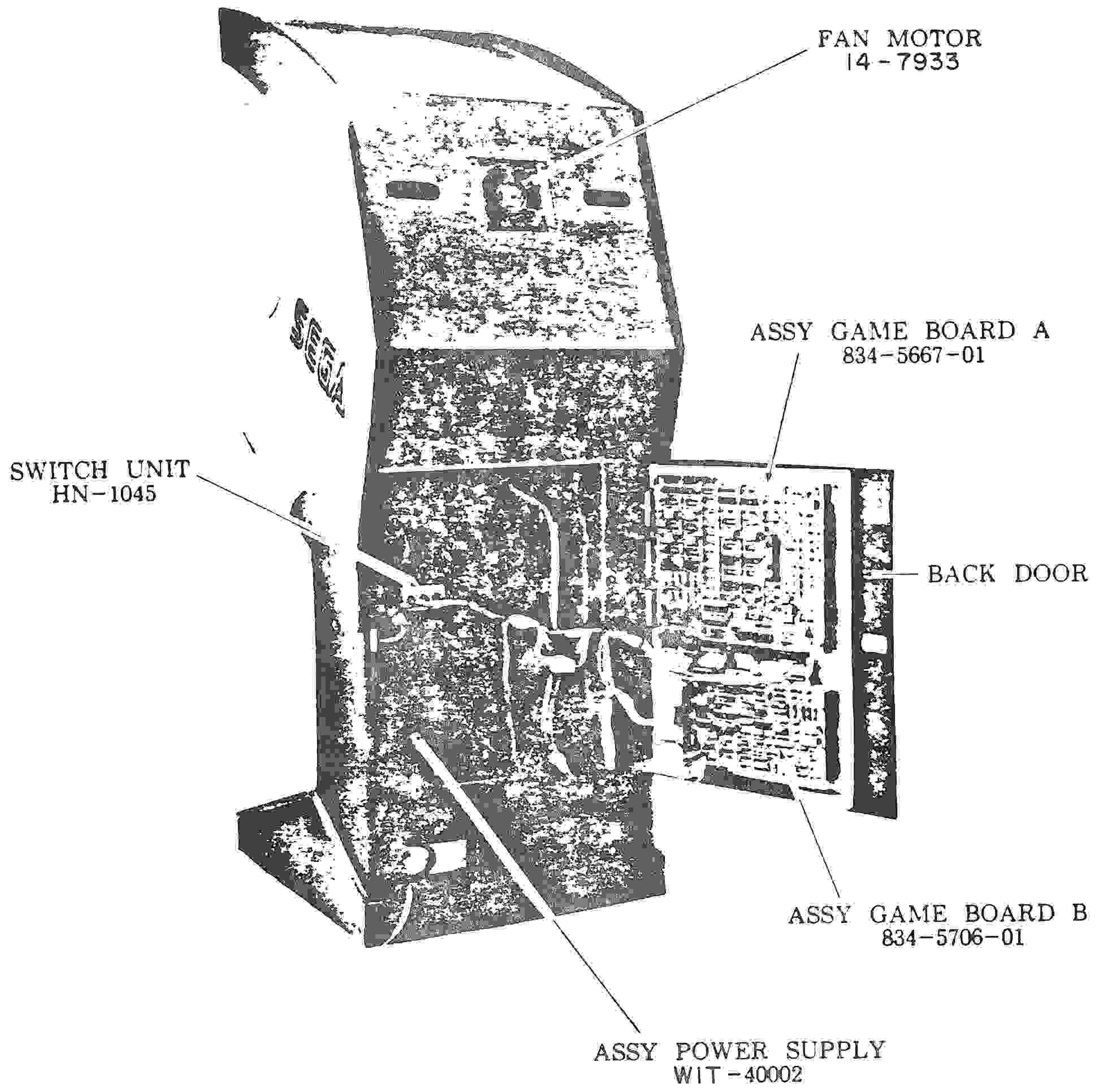

5. ADJUSTMENT OF THE SERVICE SWITCH

The layout as shown below can be viewed by opening the coin chute door.

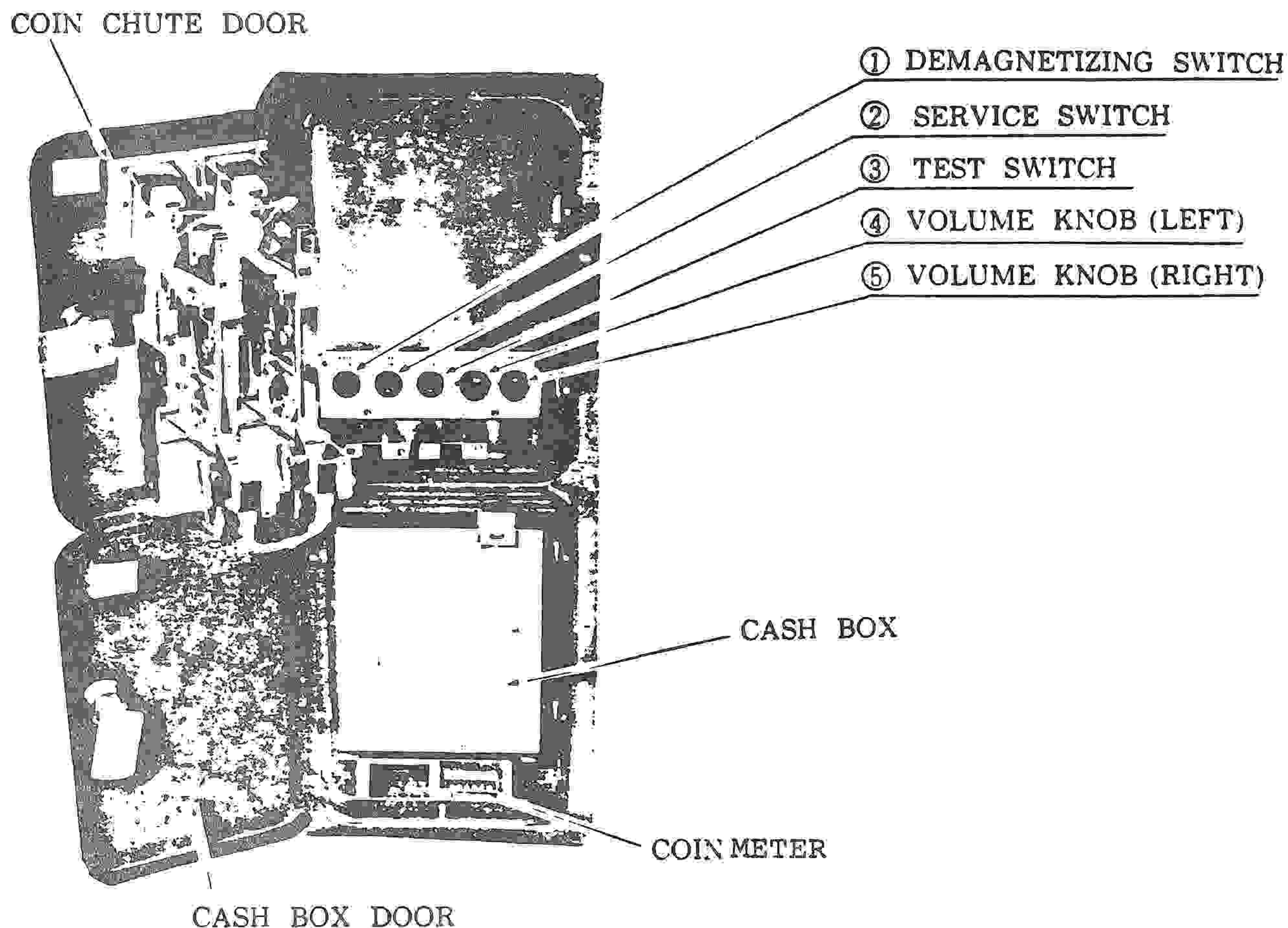

OPERATING INSTRUCTIONS

- ① DEMAGNETIZING SWITCH..... Switch not functional. Monitor automatically demagnetizes upon power up of game.
- ② SERVICE SWITCH.....Used for the purpose of servicing and increasing the credits without registering on the meter (this allows you to check the game).
- ③ TEST SWITCH.....For operating this switch, see 13 .
SELF-TESTING.
- ④ ⑤ VOLUME ADJUSTMENT.....The volume of the right/left speakers is separately adjusted (pay attention to the right/left volume balance).

6. DIP SWITCH SETTING

Game Price Settings

OPTION	DIP SW #1							
	1	2	3	4	5	6	7	8
1 COIN 1 CREDIT	OFF	OFF	OFF	OFF	OFF	OFF	OFF	OFF
1 COIN 2 CREDITS	ON	OFF	OFF	OFF	ON	OFF	OFF	OFF
1 COIN 3 CREDITS	OFF	ON	OFF	OFF	OFF	ON	OFF	OFF
1 COIN 4 CREDITS	ON	ON	OFF	OFF	ON	ON	OFF	OFF
1 COIN 5 CREDITS	OFF	OFF	ON	OFF	OFF	OFF	ON	OFF
1 COIN 6 CREDITS	ON	OFF	ON	OFF	ON	OFF	ON	OFF
2 COINS 1 CREDIT	OFF	ON	ON	OFF	OFF	ON	ON	OFF
3 COINS 1 CREDIT	ON	ON	ON	OFF	ON	ON	ON	OFF
4 COINS 1 CREDIT	OFF	OFF	OFF	ON	OFF	OFF	OFF	ON
2 COINS 3 CREDITS	ON	OFF	OFF	ON	ON	OFF	OFF	ON
2 COINS 1 CREDIT								
4 COINS 2 CREDITS	OFF	ON	OFF	ON	OFF	ON	OFF	ON
5 COINS 3 CREDITS								
6 COINS 4 CREDITS								
2 COINS 1 CREDIT	ON	ON	OFF	ON	ON	ON	OFF	ON
4 COINS 3 CREDITS								
1 COIN 1 CREDIT								
2 COINS 2 CREDITS	OFF	OFF	ON	ON	OFF	OFF	ON	ON
3 COINS 3 CREDITS								
4 COINS 4 CREDITS								
5 COINS 6 CREDITS								
1 COIN 1 CREDIT	ON	OFF	ON	ON	ON	OFF	ON	ON
2 COINS 2 CREDITS								
3 COINS 3 CREDITS								
4 COINS 5 CREDITS								
1 COIN 1 CREDIT	OFF	ON	ON	ON	OFF	ON	ON	ON
2 COINS 3 CREDITS								
1 COIN 1 CREDIT	ON	ON	ON	ON	ON	ON	ON	ON
	COIN SW #1				COIN SW #2			

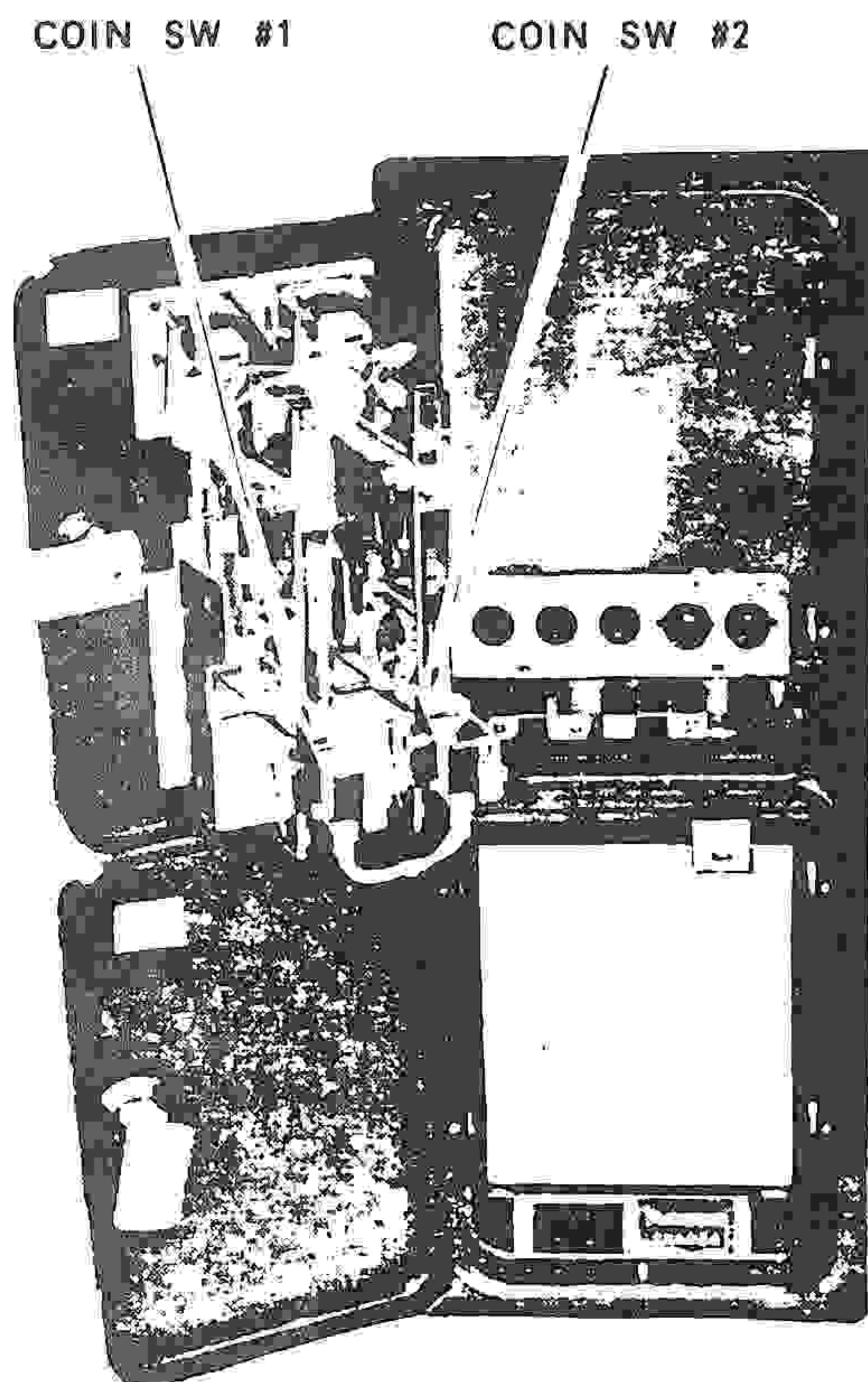

Game Option Settings

OPTION		DIP SW #2							
		1	2	3	4	5	6	7	8
ADVERTISE	OFF	OFF							
SOUND	ON	ON							
GAME	MEDIUM		OFF	OFF					OFF
DIFFICULTY	EASY		ON	OFF					
	HARD		OFF	ON					
	HARDEST		ON	ON					
TIME	EASY				OFF	OFF			
ADJUST.	MEDIUM				ON	OFF			
	HARD				OFF	ON			
	HARDEST				ON	ON			
PLAY	MUSIC	ON					OFF		
		OFF					ON		

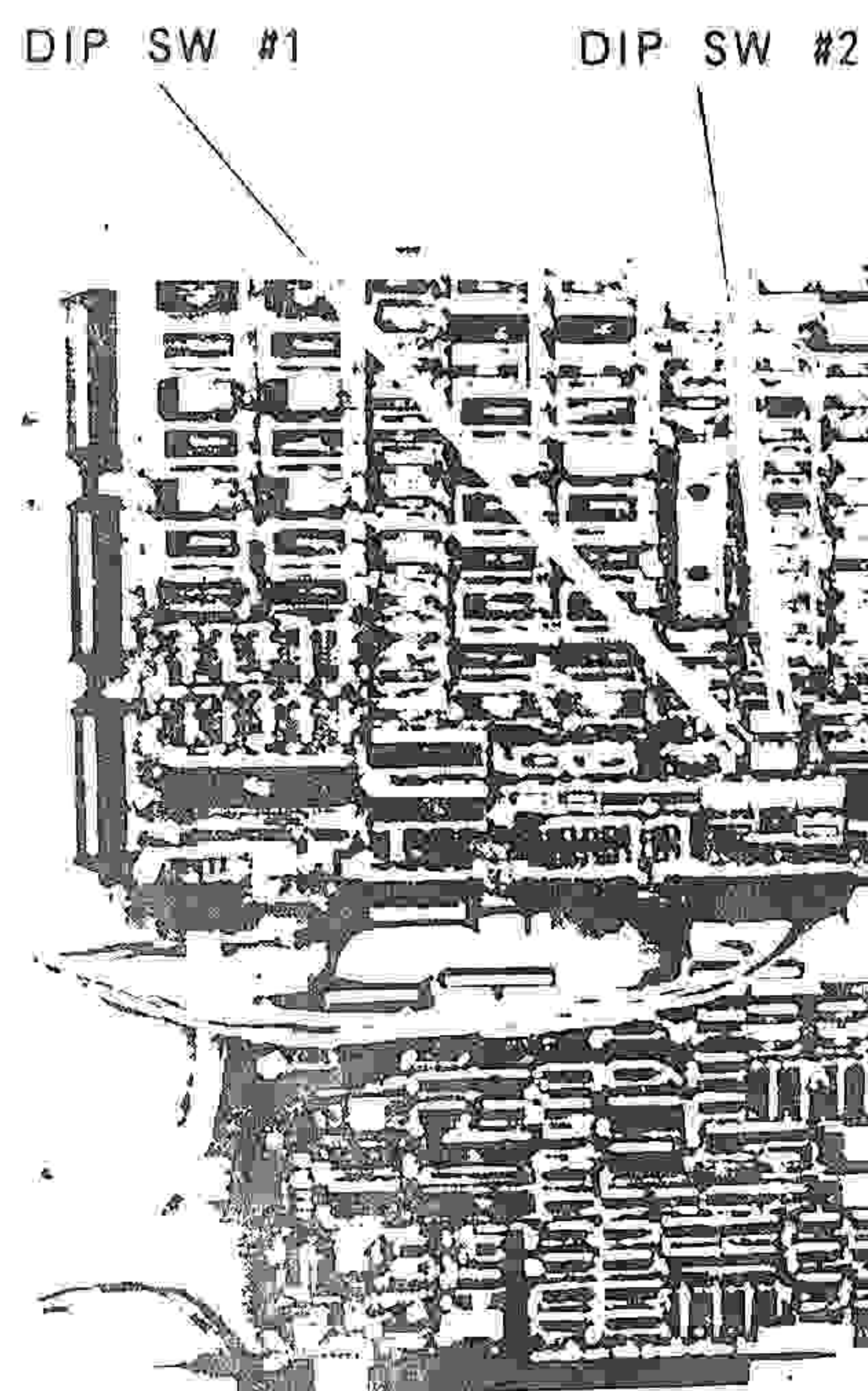

DIP SWITCH

- o For details concerning the difficulty level setting, see page 8 .

7. SETTING THE DIFFICULTY LEVEL FOR THE " UPRIGHT " TYPE

For the UPRIGHT type HANG-ON machine, the difficultness of the game can be set for 4 different levels by adjusting ①, the other cars' appearance frequency and ②, the game time, using DIP SWITCH No. 2 on the PC (printed circuit) board. Depending on the skills of the players, appropriate difficulty levels can be set as applicable. When shipping the machine, the difficulty levels for both the above-mentioned ① and ② are set for the * mark level.

① Other cars' appearance frequency (set by DIP SWITCHES 2 & 3)

SWITCH NO.		The other cars' appearance frequency	Difficulty level
3	2		
OFF	OFF	—————	MEDIUM
OFF	ON	30% lower than MEDIUM	EASY
ON	OFF	40% higher than MEDIUM	HARD
ON	ON	80% higher than MEDIUM	HARDEST

*←When shipping

② Game time adjustment (set by DIP SWITCH 4 & 5)

SWITCH NO.		Game time (seconds) per stage					Difficulty level
5	4	1	2	3	4	5	
OFF	OFF	75	60	55	55	50	EASY
OFF	ON	70	60	60	55	55	MEDIUM
ON	OFF	65	60	55	60	55	HARD
ON	ON	60	60	60	60	55	HARDEST

*←When shipping

DETAILED EXAMPLES

DIP SW NO.				Difficulty level
5	4	3	2	
OFF	OFF	OFF	ON	1
OFF	ON	OFF	ON	2
ON	OFF	OFF	ON	3
ON	ON	OFF	ON	4
OFF	OFF	OFF	OFF	5
OFF	ON	OFF	OFF	6
ON	OFF	OFF	OFF	7
ON	ON	OFF	OFF	8
OFF	OFF	ON	OFF	9
OFF	ON	ON	OFF	10
ON	OFF	ON	OFF	11
ON	ON	ON	OFF	12
OFF	OFF	ON	ON	13
OFF	ON	ON	ON	14
ON	OFF	ON	ON	15
ON	ON	ON	ON	16

EASY



* When shipping



HARDEST

8. HANDLE'S CENTERING ADJUSTMENT

- o When the HANDLE is in a stationary position, display the following on the screen in the SELF-TEST mode:
- o At this time, if the variable value becomes 80H, it is considered normal.

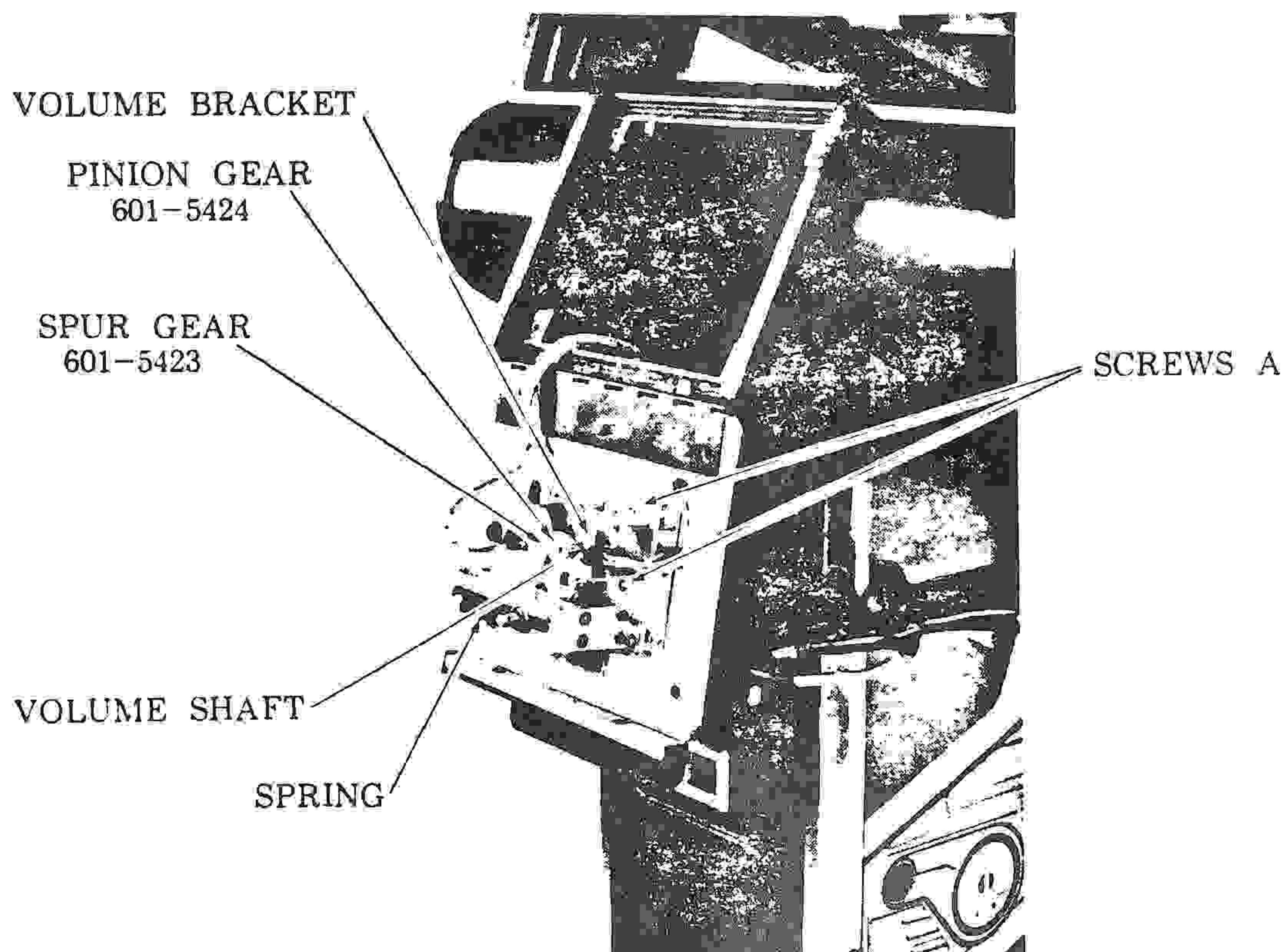

ADJUSTING PROCEDURE

- ① The VOLUME BRACKET can be moved in the right and the left directions by releasing 2 SCREWS A which fasten it.
- ② Move the VOLUME BRACKET to the right to disengage the PINION GEAR and the SPUR GEAR. At this time, make adjustments by turning the VOLUME SHAFT in a manner so that the variable value falls within the allowable range.
- ③ In the case where fine adjustments are necessary, slightly release the VOLUME BRACKET and then turn it in the applicable direction.

DIAGNOSTIC INPUT TEST		
COIN # 1		START
COIN # 2		SERVICE
FOOT SW R		FOOT SW L
ANGLE	DATA	80H ←
ACCEL	DATA	00H
BRAKE	DATA	00H

VARIABLES

9. ADJUSTING THE ACCELERATOR / BRAKE

- o After replacing the ACCELERATOR/BRAKE WIRES, carry out the following test:
- o Display the following on the screen in the SELF-TEST MODE (see page 15).

ACCELERATOR

- o When the ACCELERATOR is returned to its original OFF position, make adjustment in a manner so that the variable value becomes 0H.
Allowable range: 0H-4H
- o Make adjustment of the wire's length by using NUT C (see page 24).

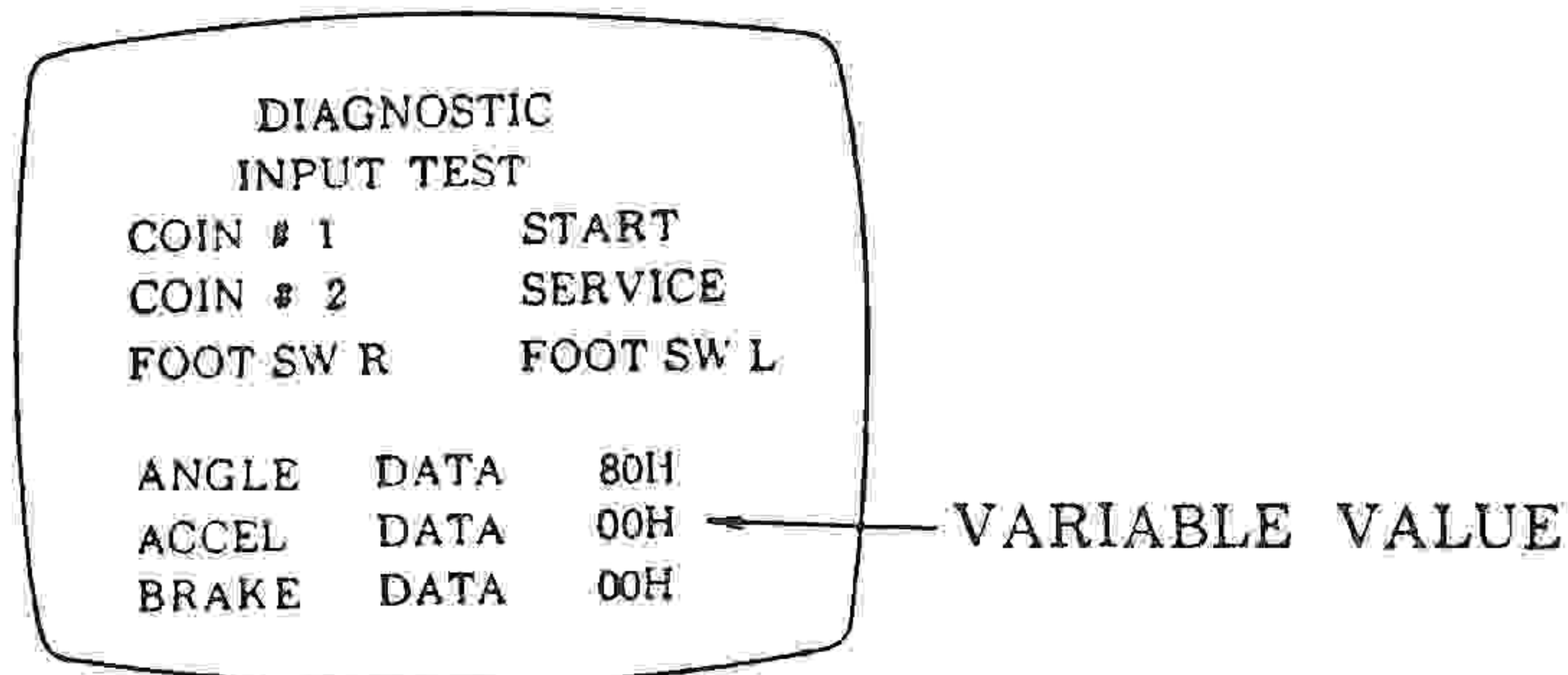

BRAKE

When the ACCELERATOR is returned to its original OFF position, make sure that the VARIABLE VALUE becomes 0H.

Allowable range: 0H-4H

- o Adjust the wire's length by using NUT C (see page 24).

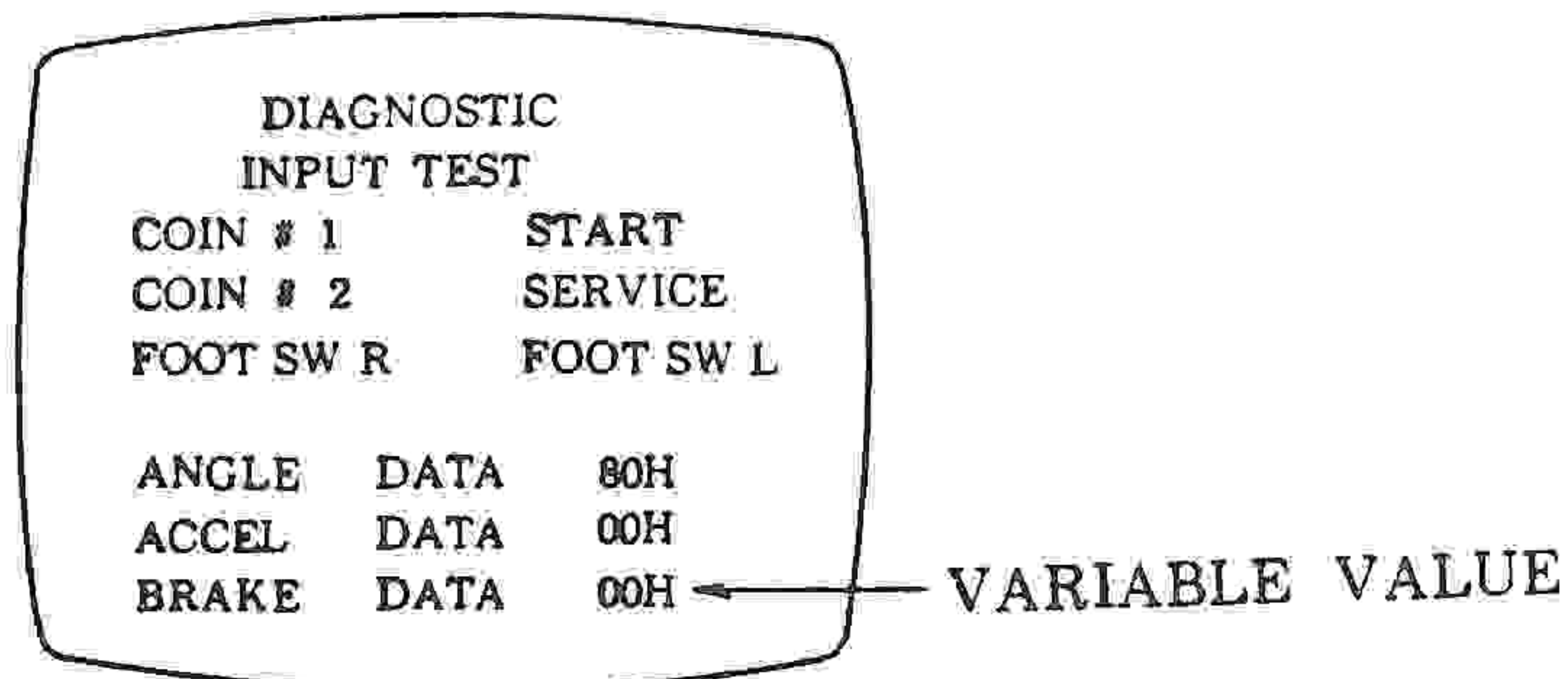

- o When the ACCELERATOR/BRAKE is moved the maximum distance, the PINION GEAR (see page 24). turns approximately 180 degrees.

10. EPROM LOCATION

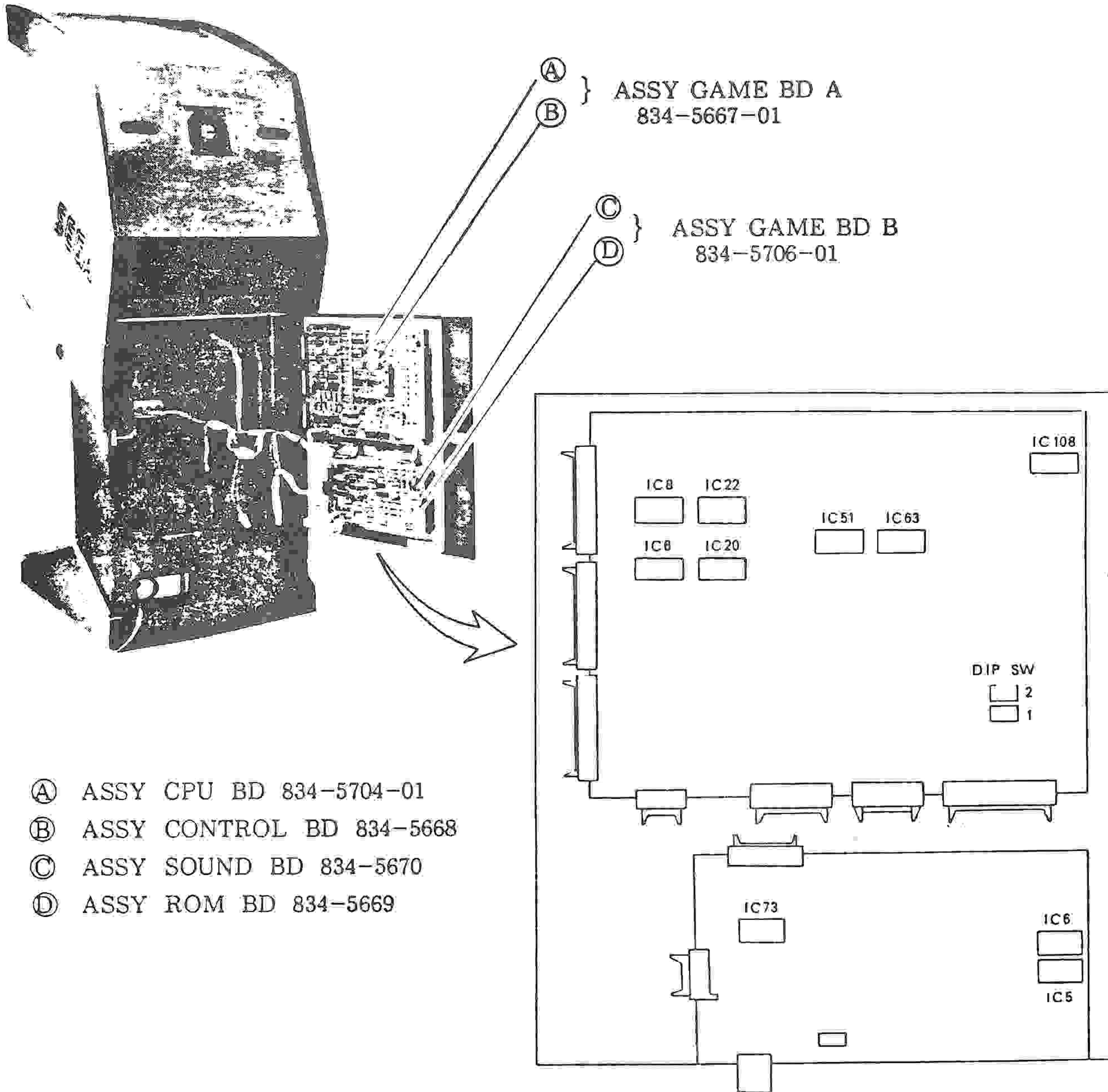

- Ⓐ ASSY CPU BD 834-5704-01
- Ⓑ ASSY CONTROL BD 834-5668
- Ⓒ ASSY SOUND BD 834-5670
- Ⓓ ASSY ROM BD 834-5669

Ⓐ ASSY CPU BD 834-5704-01

IC LOCATIONS	NUMBERS	MAIN FUNCTIONS
1	IC 6	EPR-6915A MAIN PROGRAM
2	IC 8	EPR-6916A MAIN PROGRAM
3	IC 20	EPR-6917A MAIN PROGRAM
4	IC 22	EPR-6918A MAIN PROGRAM
5	IC 51	EPR-6919 SUB PROGRAM
6	IC 63	EPR-6920 SUB PROGRAM
7	IC 108	EPR-6840 ROAD CHARACTER

Ⓑ ASSY CONTROL BD 834-5668

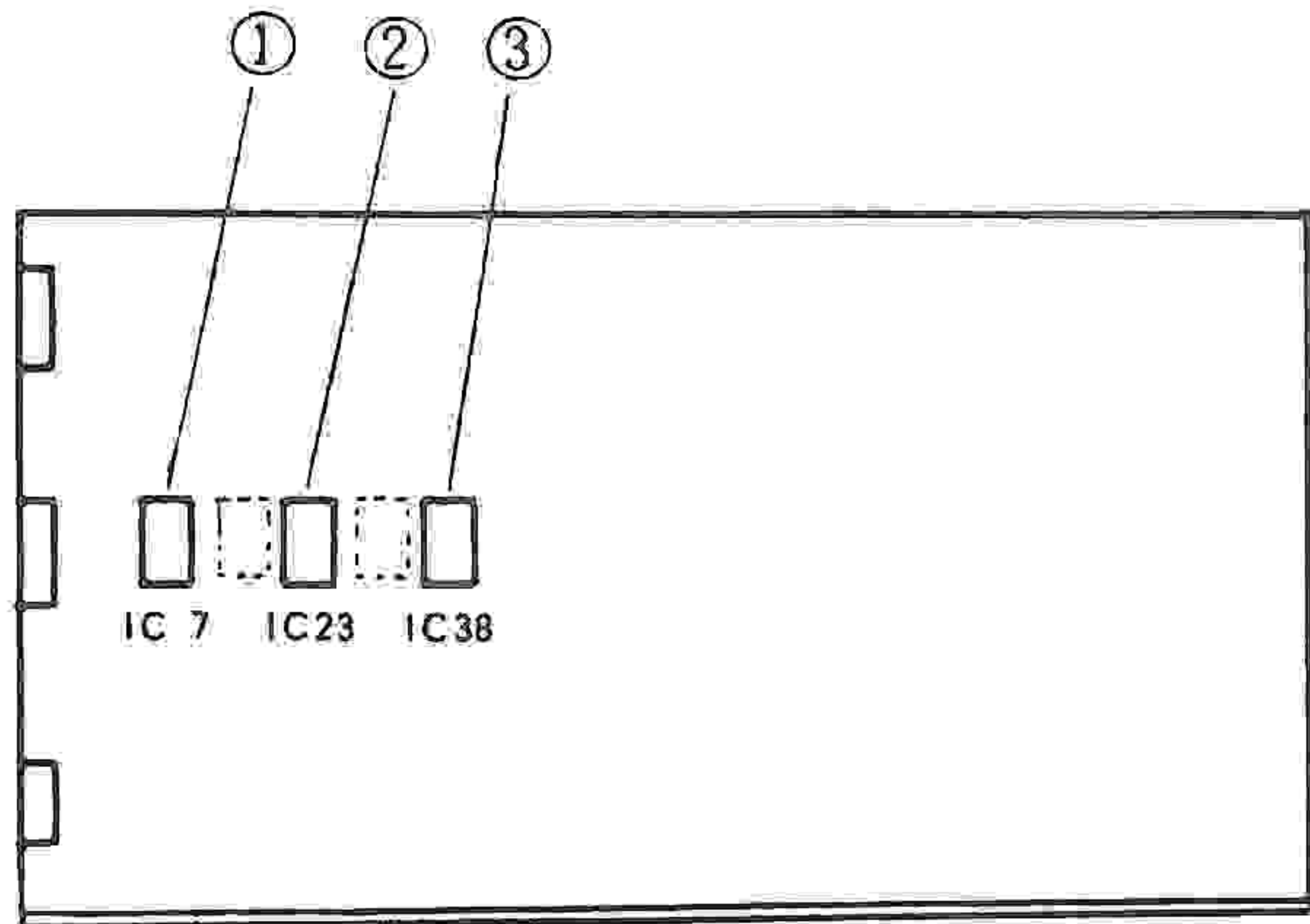

IC locations	Numbers	Main functions
1	IC 7	Letters & characters
2	IC 23	
3	IC 38	

Ⓒ ASSY SOUND BD 834-5670

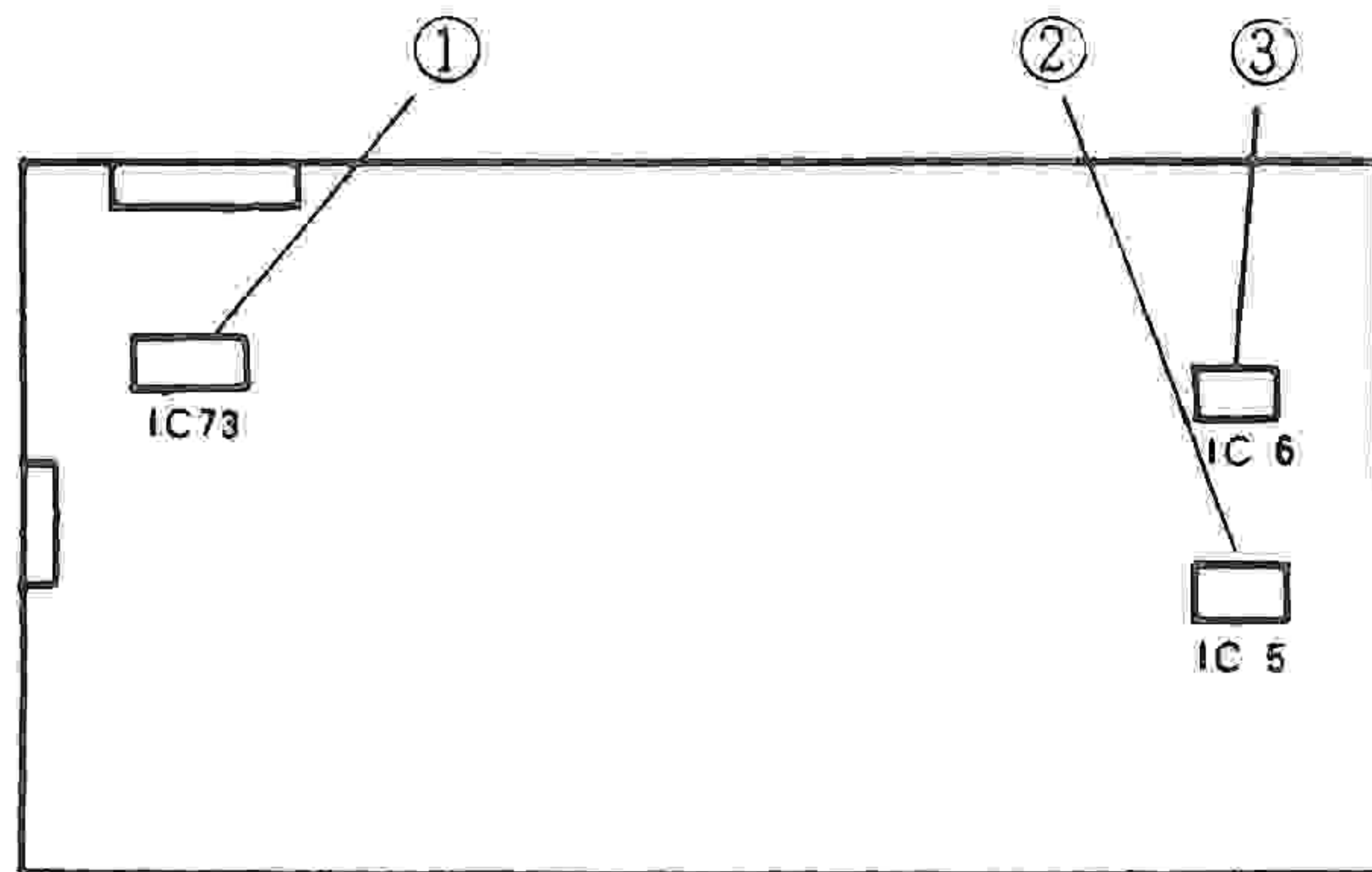

IC locations	Numbers	Main functions
1	IC 73	Driving and other sounds
2	IC 5	
3	IC 6	

Ⓓ ASSY ROM BD 834-5669

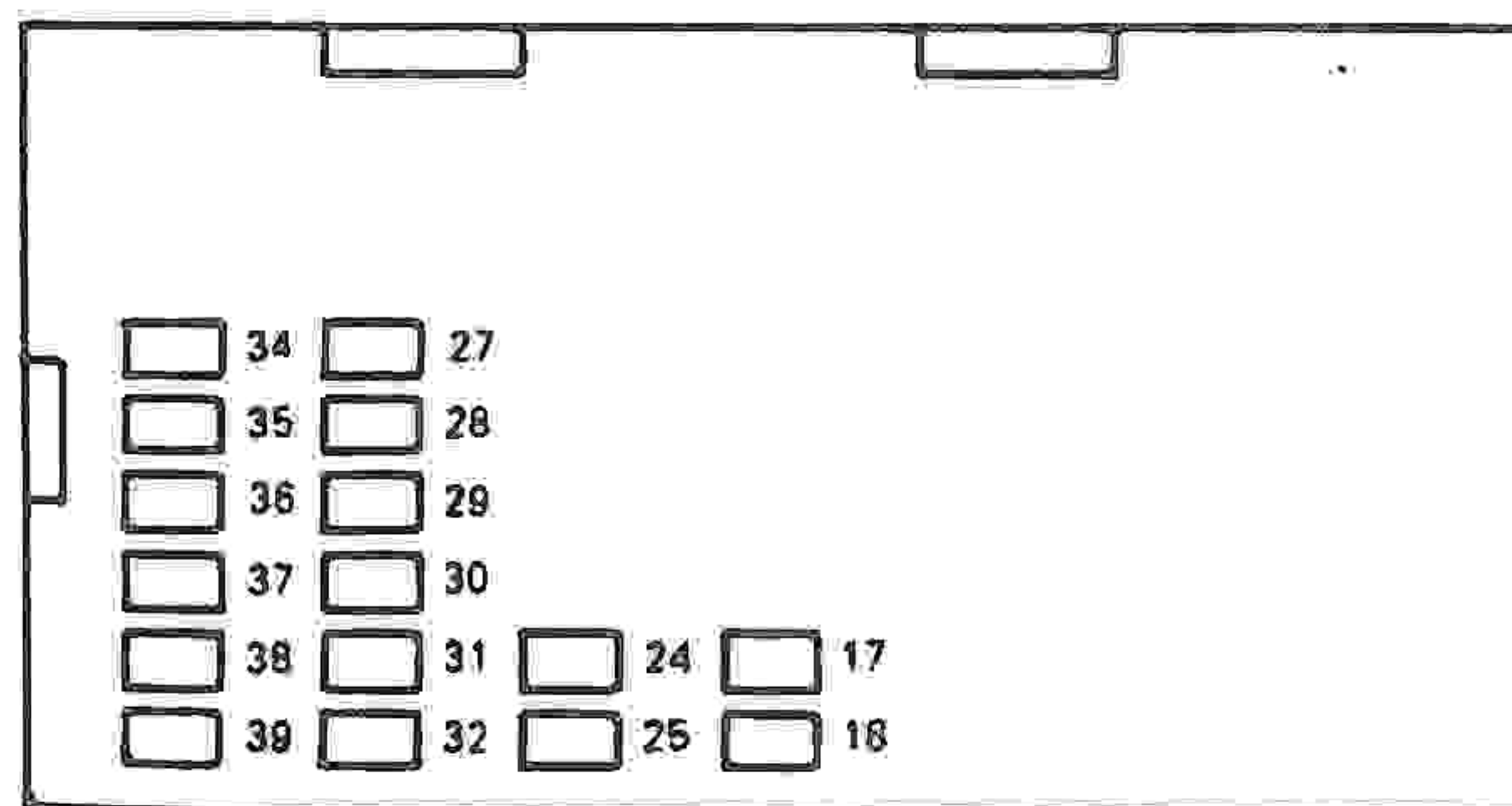

IC locations	Numbers	Main functions
1	IC 27	Scenery figures
2	IC 34	
3	IC 28	
4	IC 35	
5	IC 29	
6	IC 36	
7	IC 30	
8	IC 37	
9	IC 31	
10	IC 38	
11	IC 32	
12	IC 39	
13	IC 18	
14	IC 25	

11. SELF-TESTING

The main purpose of these tests are to check the operations of the game boards, to find the defects if any, to adjust the monitor colors properly, and to make sure the sounds are produced satisfactorily. It is also performed to indicate the assignments of the dip switches, check bookkeeping functions, etc.

KIND OF TESTS

- 1) Memory Test: To check the EPROM programs and the map area of the RAMs.
- 2) Input Test: To check the machine's inclining angle and to test the operation of the accelerator, brake, coin switches, etc.
- 3) Output Test: To test the operation of the start lamp.
- 4) Sound Test: To check the quality of the sounds produced by the PCB and the video disc, and adjust the balance of the speakers.
- 5) CRT Test: To check if the colors on the monitor are displayed correctly, and to adjust the linearity.
- 6) Dip Switch
Assignment: To indicate each dip switch assignment.
- 7) Bookkeeping: To indicate information data on average score and average play time, etc.

1. TEST OPERATION

- (1) Push the test switch and Fig. 1 will be shown on the screen.
- (2) Select CONTINUE or INDIVIDUAL by using the START button.

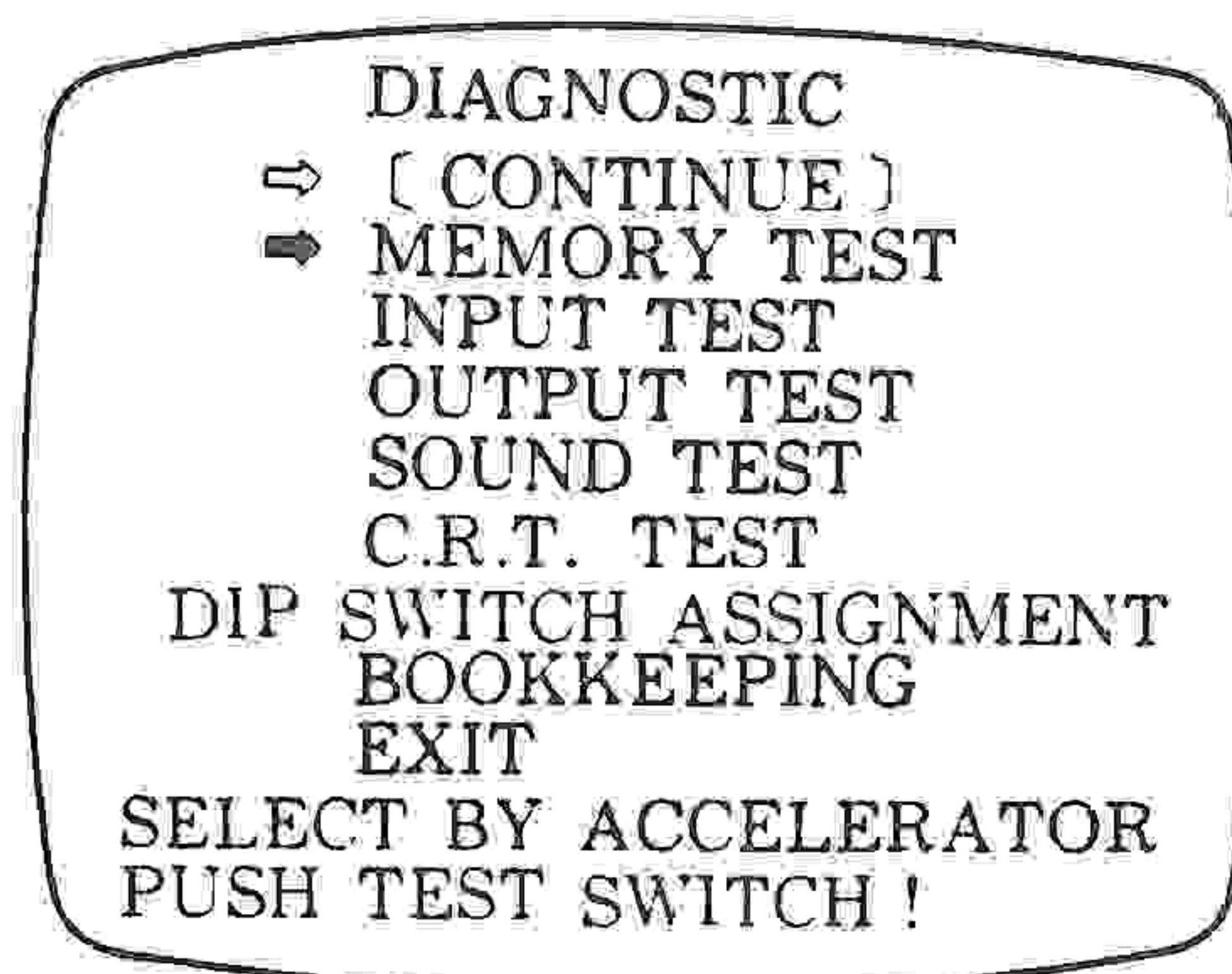

FIG. 1

- (3) Move the accelerator to bring the arrow to the desired position.

SELECT BY ACCELERATOR PUSH TEST SWITCH
(Select the desired test item by using the accelerator and push the test switch button.)

[CONTINUE]:

- o Bring the arrow sign (by operating the control lever) to CONTINUE first, and move it to one of the tests to start. Push the TEST button, and the tests will be performed in order, one by one, starting from the test where the arrow was originally set to the EXIT.
- o If the START button is pushed when the arrow is at CONTINUE, it will change to INDIVIDUAL. Pushing it again returns it to CONTINUE.

[INDIVIDUAL]:

- o If the arrow is at INDIVIDUAL first and brought to a certain test which you want to conduct, only that test is performed by pushing the TEST button.

(4) When each test is finished in the case of CONTINUE, push the TEST button, and it will automatically go into the following test. If the TEST button is pushed in the case of INDIVIDUAL, FIG. 1 is shown. If you want to end the test mode at this time, bring the arrow to EXIT and push the TEST button, and it will return to the ADVERTISEMENT mode.

2. TEST ITEMS

(1) Memory Test:

```

DIAGNOSTIC
MEMORY TEST

** ROMS TEST **
IC 8 GOOD IC 6 GOOD IC 51 GOOD
IC 22 GOOD IC 20 GOOD IC 63 GOOD

** RAMS TEST **
IC 54 GOOD IC 74 GOOD IC 90 GOOD
IC 66 GOOD IC 75 GOOD IC 104 GOOD
IC 73 GOOD IC 2 GOOD IC 10 GOOD
IC 52 GOOD IC 1 GOOD IC 24 GOOD
IC 46 GOOD IC 58 GOOD
  
```

Indication of "GOOD" following the IC No. means the IC is all right. Push the TEST button to proceed to the following test item.

(2) Input Test

```

DIAGNOSTICS
INPUT TEST

COIN # 1      START
COIN # 2      SERVICE
FOOT SW R    FOOT SW L
ANGLE DATA  80H
ACCEL DATA  00H
BRAKE DATA  00H
  
```

→ Applicable only for the RIDE ON type (not the UPRIGHT type).

1. Operate the dip switches. When "ON" is indicated at the right side of a certain tested item, the item is OK.
 2. If the DATA value decreases when the bike is inclined to the right, or increases when it is inclined to the left the testing is OK (the data is indicated in the form of hexadecimal values). Make adjustment in a manner so that in the static condition the value shows 80H.
 3. If the data value increases when the accelerator/brake is applied and the value ranges between "00H" and "4H" when it is returned to its original position, then the item test is OK.
- o When the test is ended, push the TEST button.

(3) Output Test

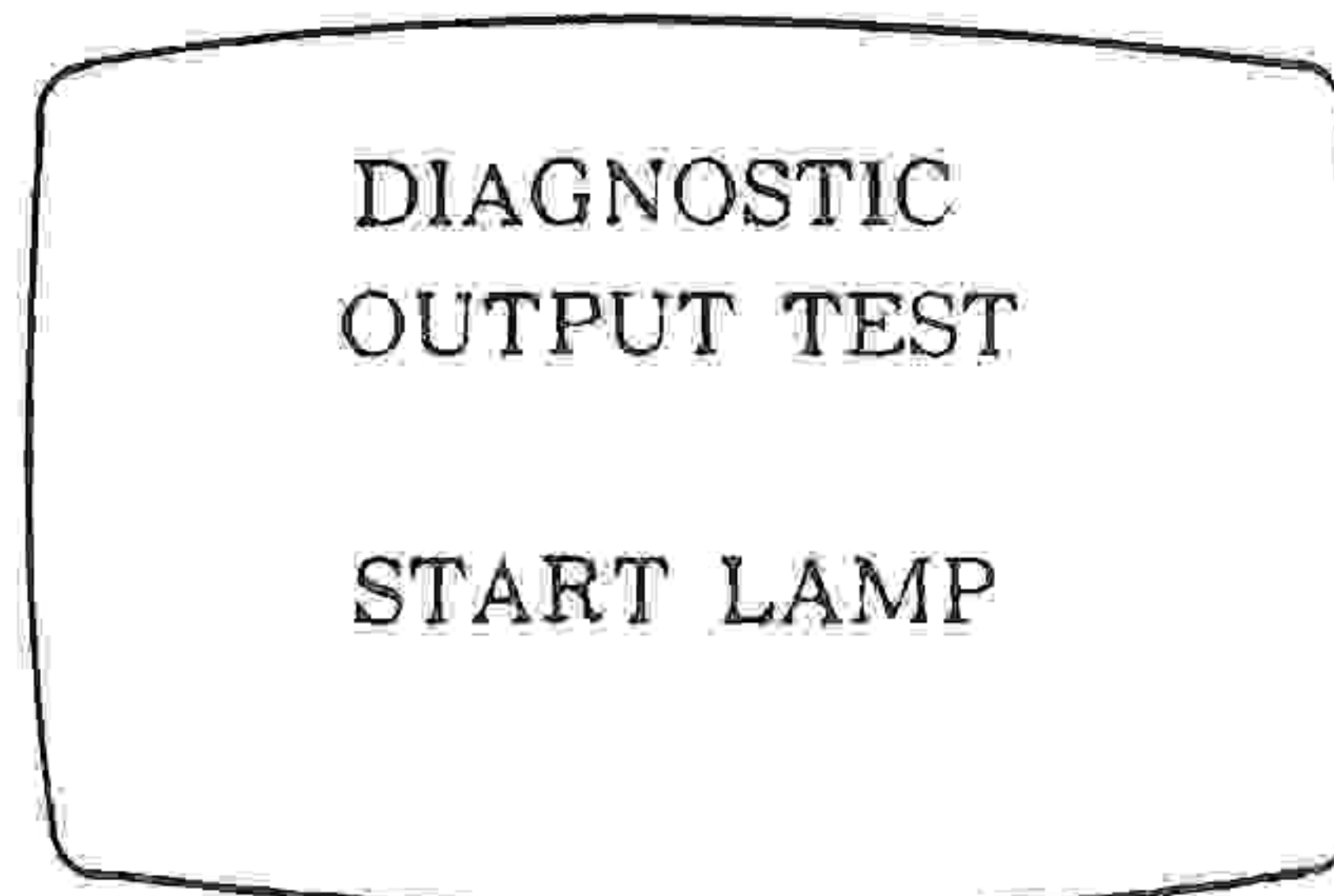

If the start LAMP lights up, it is functioning properly.
Push the TEST button when the testing has been completed.

(4) Sound Test

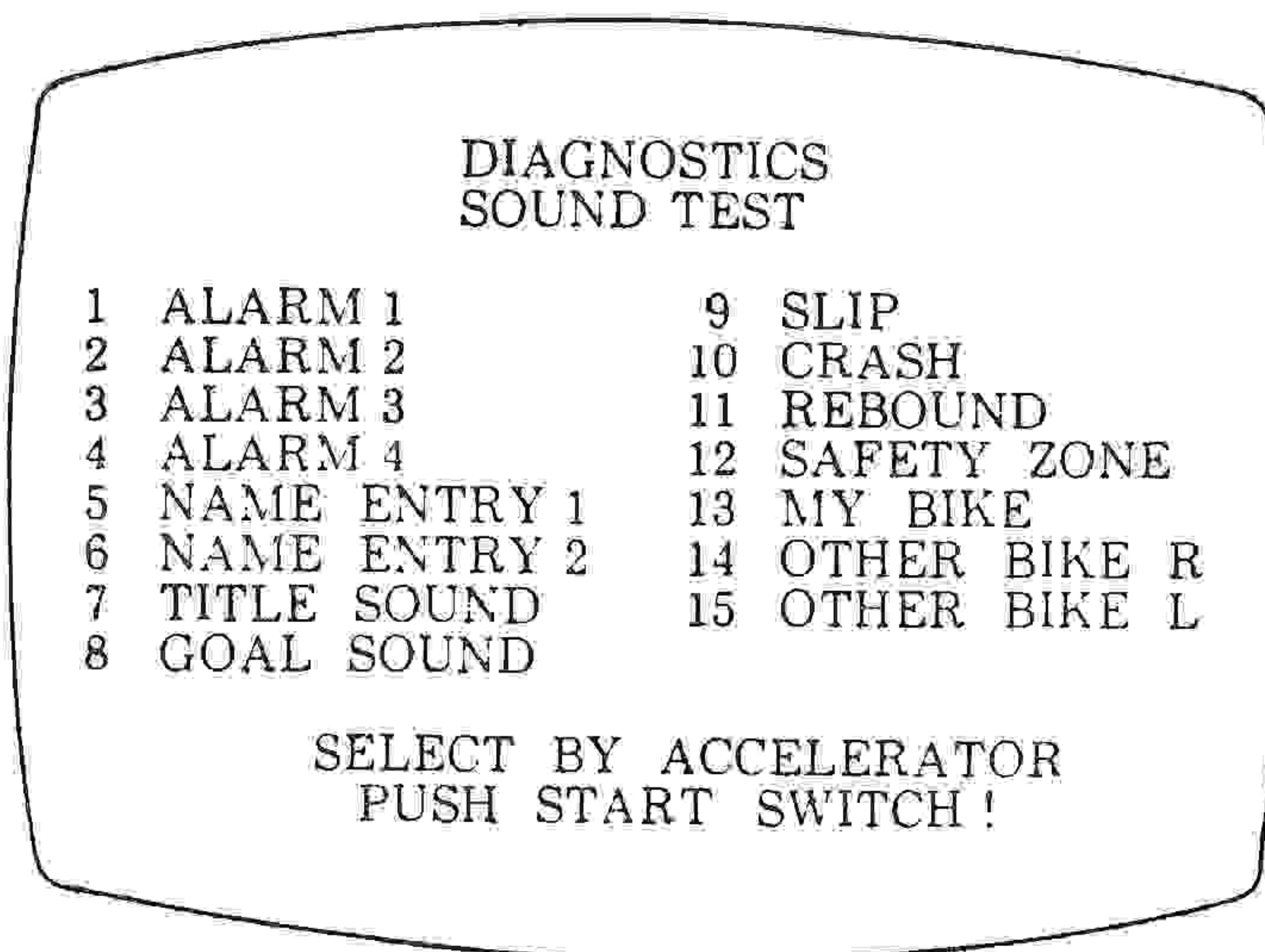

When the test has been completed, push the TEST button.

(5) C.R.T. TEST

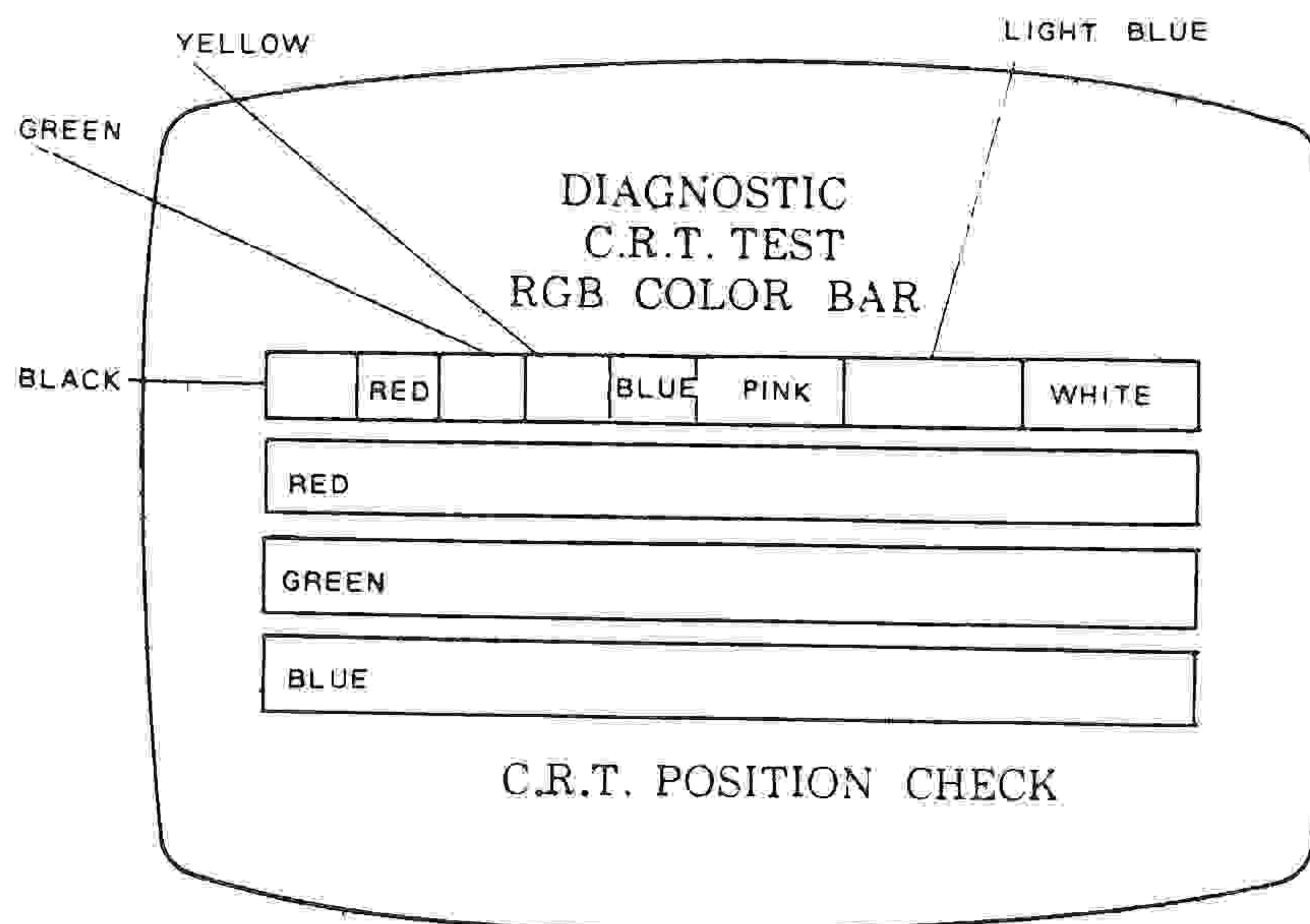

When the test has been completed, push the TEST button.

(6) DIP SWITCH ASSIGNMENTS

DIAGNOSTIC									
DIP SWITCH ASSIGNMENTS									
	1	2	3	4	5	6	7	8	
DIP SW. 1	OFF	OFF	OFF	OFF	OFF	OFF	OFF	OFF	Present setting of the Dip Switches.
DIP SW. 2	OFF	OFF	OFF	OFF	OFF	OFF	OFF	OFF	Coin Switch Setting.
1 1 2 3 4	COIN SW #1		1 COIN	1 CREDIT					
1 5 6 7 8	COIN SW #2		1 COIN	1 CREDIT		With or without sound on the ADVERTISEMENT mode.			
2 1	ADVERTISE SOUND		Setting of the game difficulty level.						
2 2 3	GAME DIFFICULTY								
2 4 5	TIME ADJ.		Setting of the game difficulty level by time.						
2 6	PLAY MUSIC								

(7) Bookkeeping information

DIAGNOSTIC		
BOOKKEEPING		
COIN CHUTE #1	0	Usage frequency of coin chute 1
COIN CHUTE #2	0	Usage frequency of coin chute 2
COIN CREDIT	0	Number of coin credits
SERVICE CREDIT	0	Usage frequency of service switch
TOTAL CREDIT	0	Number of credits
TOTAL TIME	<input type="checkbox"/> H <input type="checkbox"/> M <input type="checkbox"/> S	Operating time (hour-minute-second)
PUSH START BUTTON !		

* Only the data that falls within the range of up to 999H 59M 59S can be memorized. The above screen indication is for testing. When the tests are finished, push the START button and the following will be shown:

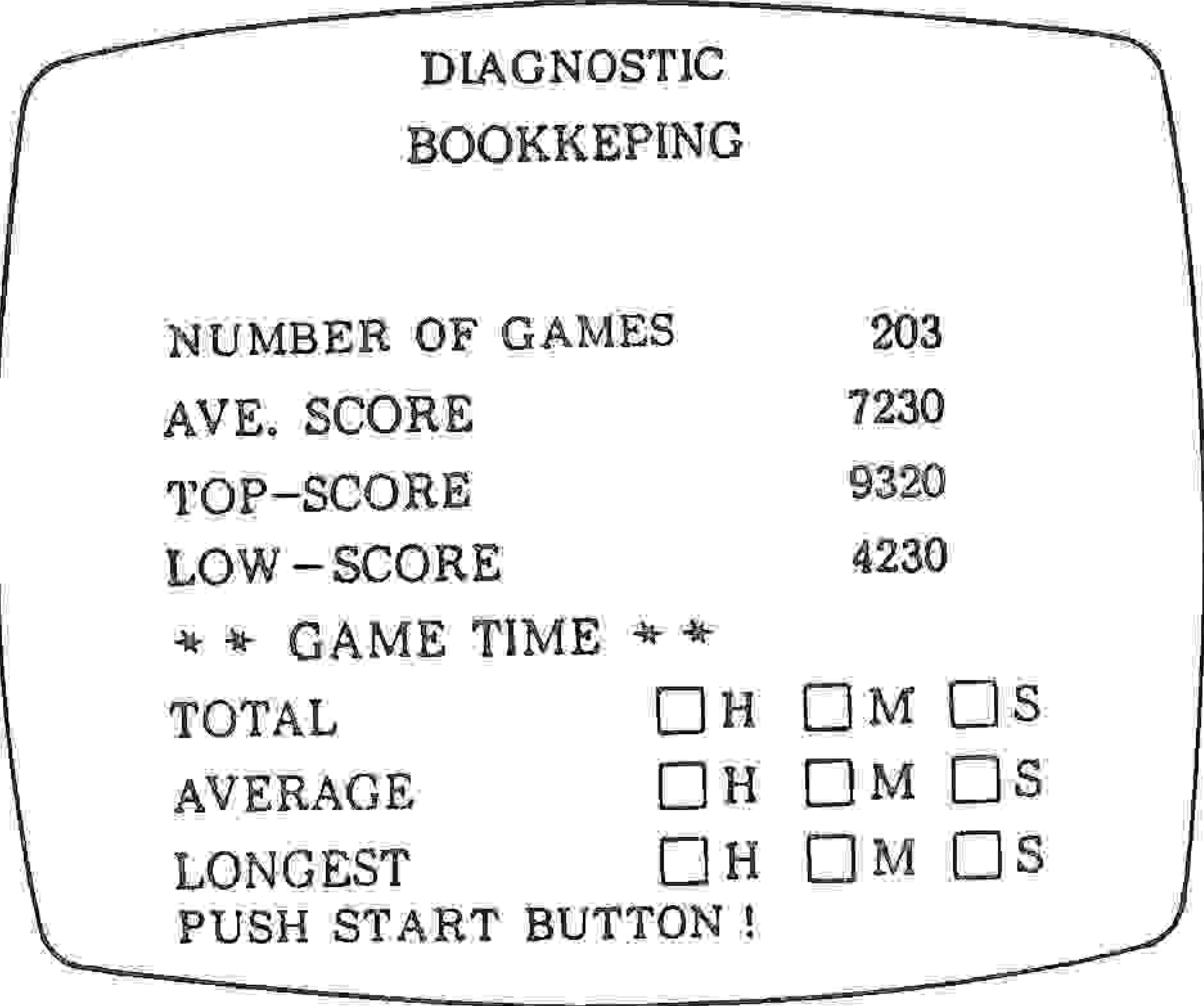

Every time the TEST button is pressed, the bookkeeping test display is repeated. When the test is finished, push the TEST button to end the test (in the case of "INDIVIDUAL", however, the test mode returns to Fig. 1 first).

- NOTE:
- o Once the power source is turned OFF, all the bookkeeping data will be completely cleared.
 - o If any data exceeds the bookkeeping function's capacity, "OVERFLOW" will be indicated on the screen and result in the stoppage of said function. At this time, turn the power OFF and turn it back ON again for reuse.

(8) EXIT

In the state as shown in Fig. 1, operate the handle to bring the arrow to EXIT and push the TEST button. The self-testing will then end and return to the ADVERTISING mode.

12. REMOVING THE HANDLE COVER

1. When adjusting the ACCELERATOR, BRAKE, etc., remove the HANDLE COVER by using the following procedure:

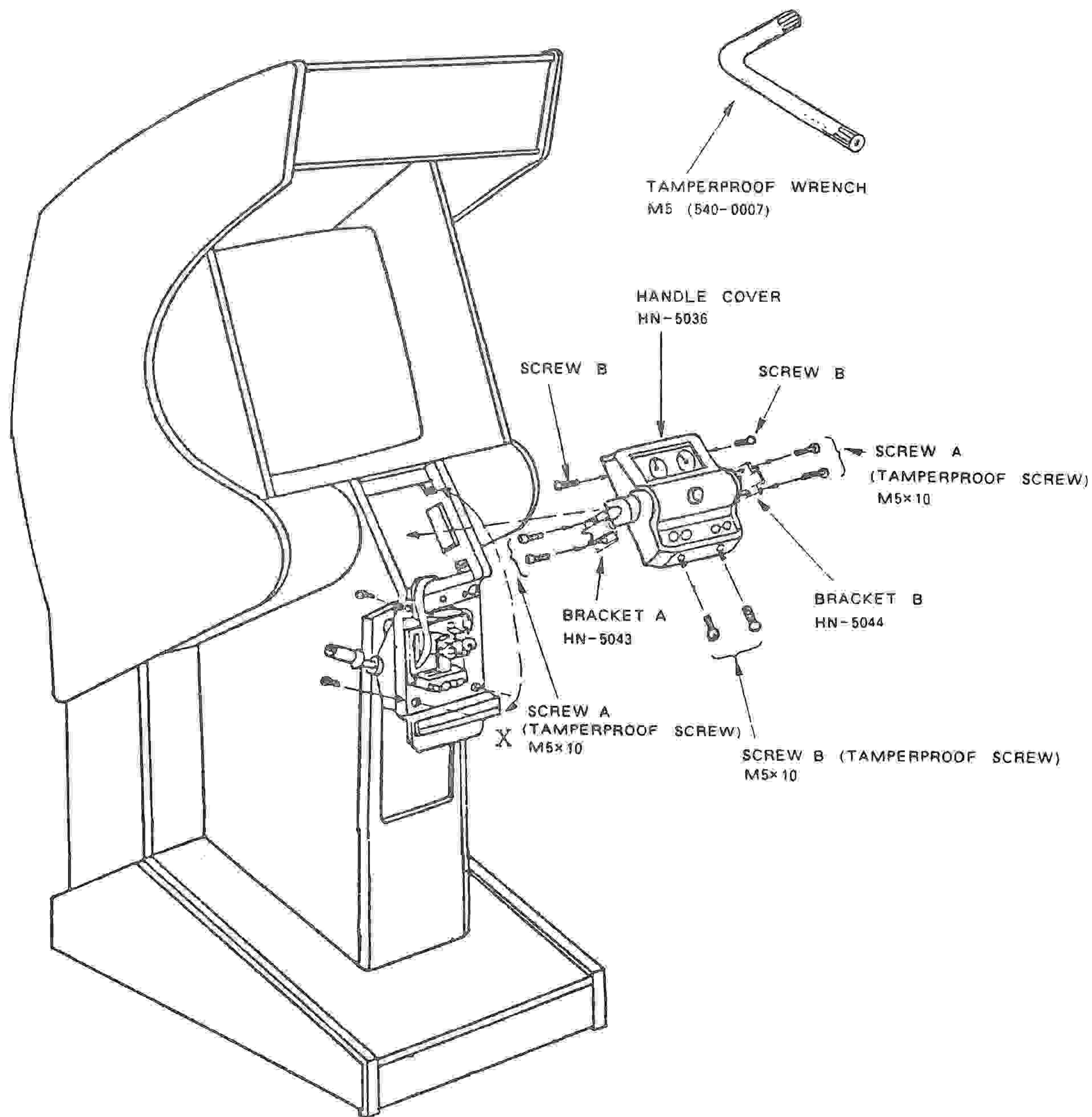

DISASSEMBLING PROCEDURE

- ① Remove 4 SCREWS A which fasten BRACKET A and BRACKET B by using the TAMPERPROOF WRENCH (M5).
- ② Remove 4 SCREWS B which fasten the HANDLE COVER by using the TAMPERPROOF WRENCH (M5).
- ③ The HANDLE COVER can be detached from the HANDLE UNIT in accordance with the above procedures ① and ②. It is completely removable from the MAIN CABINET by pulling out the CONNECTOR (orange, 4P).

13. REMOVING THE HANDLE UNIT

- o When adjusting the ACCELERATOR VOLUME and BRAKE VOLUME, remove the HANDLE UNIT by using the following procedure:

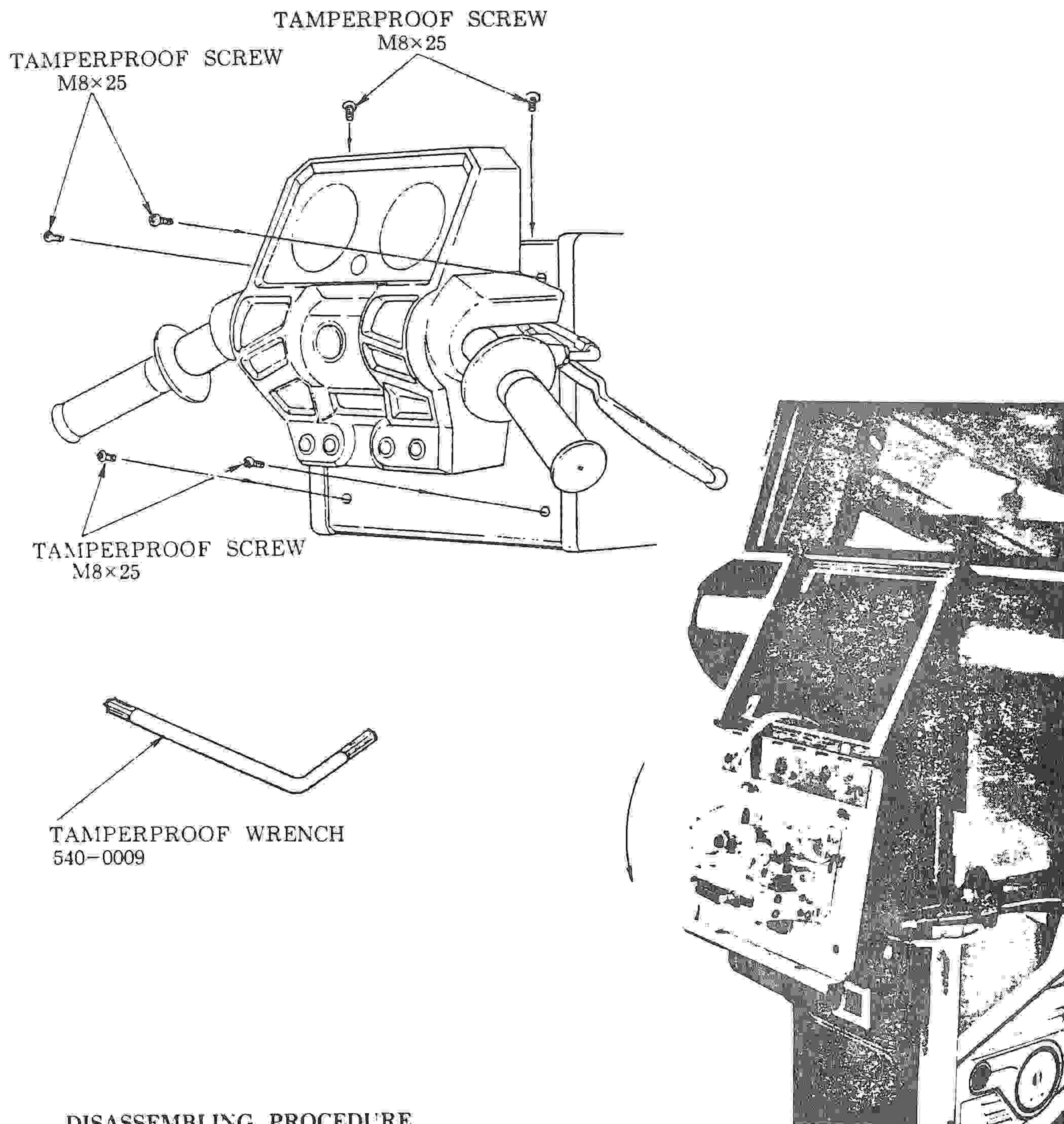

DISASSEMBLING PROCEDURE

For the adjustment of the ACCELERATOR/BRAKE volumes, take off the 6 TAMPERPROOF SCREWS by using the TAMPERPROOF WRENCH and remove the HANDLE UNIT as shown above. Refer to the separate item, ADJUSTING THE ACCELERATOR/BRAKE VOLUMES.

14. REMOVING THE WINDOW MASK

- o When cleaning the monitor screen, the back of the WINDOW GLASS, the PLASTIC PLATE, etc., remove the WINDOW MASK from the CABINET by using the following procedure:

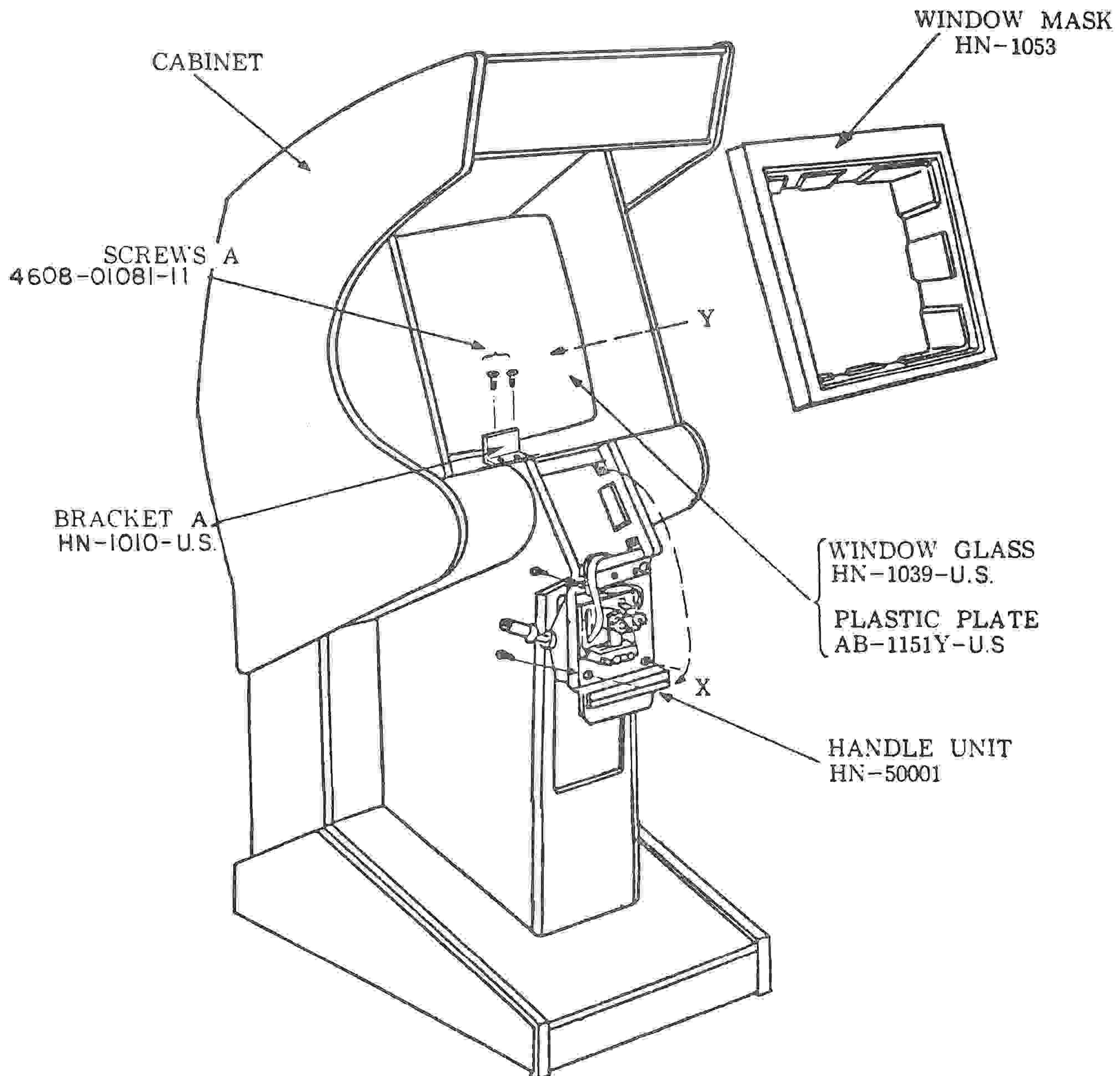

PROCEDURE

- ① Refer to REMOVING THE HANDLE UNIT (page 21).
The HANDLE UNIT can be opened in the direction of X and then the WINDOW MASK removed in the direction of Y.
- ② Remove BRACKET A which fastens the WINDOW GLASS by taking off 2 SCREWS A. In the above procedure, the WINDOW GLASS and the PLASTIC PLATE can be removed for cleaning from the CABINET.

15. REPLACING THE ACCELERATOR / BRAKE VOLUME CONTROLS

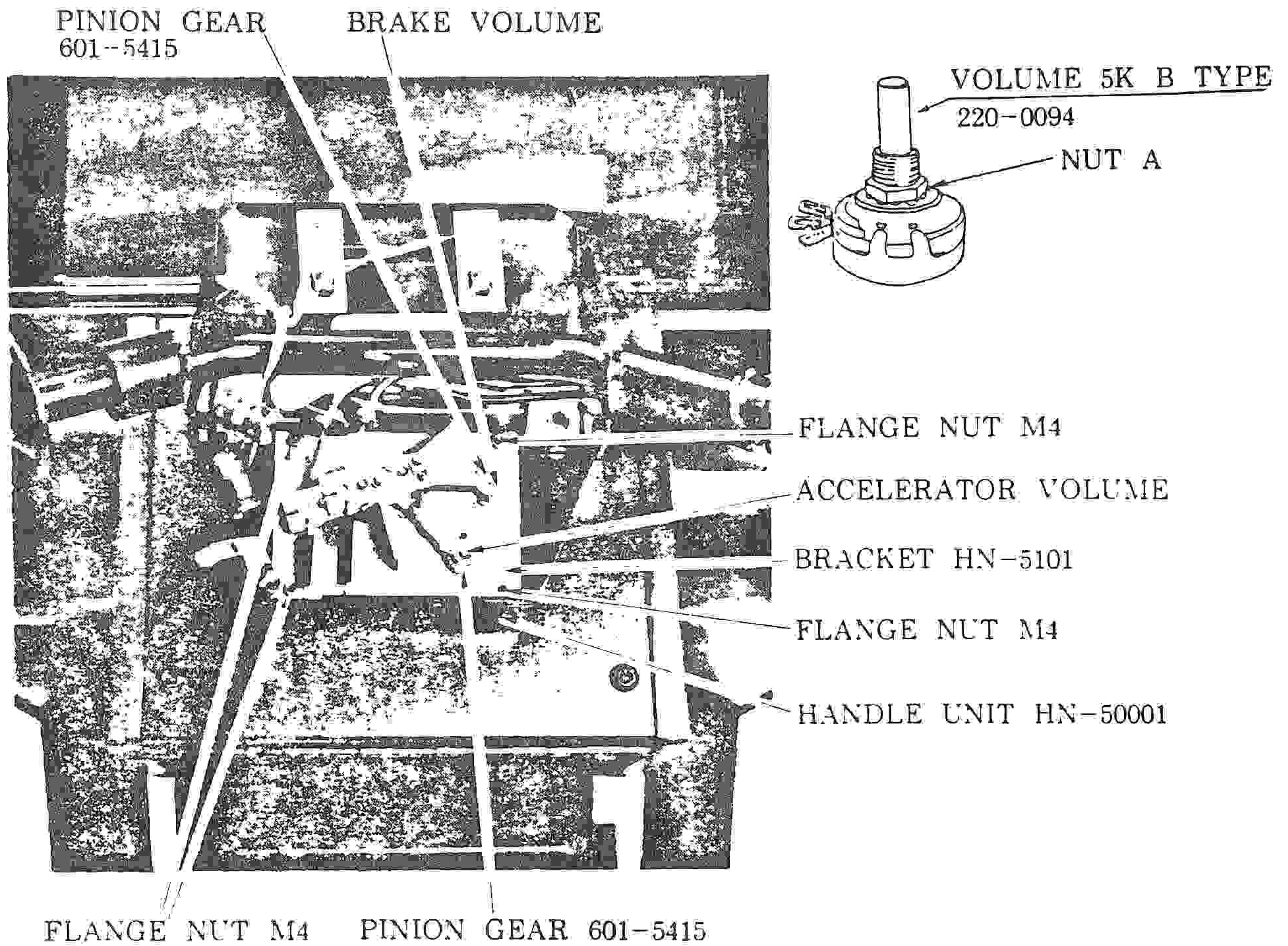

DISASSEMBLING PROCEDURE

1. To remove the BRACKET from the HANDLE UNIT, take off the 4 FLANGE NUTS which fasten the BRACKET.
2. To remove the PINION GEAR attached to the VOLUME SHAFT to be replaced, release the 2 SET SCREWS that fasten the PINION GEAR.
3. The VOLUME CONTROL can be removed from the BRACKET by taking off the VOLUME SHAFT'S NUT A.
4. After the replacement has been made, reassemble them in sequential order opposite from the above procedure.

16. REPLACING THE ACCELERATOR / BRAKE WIRES

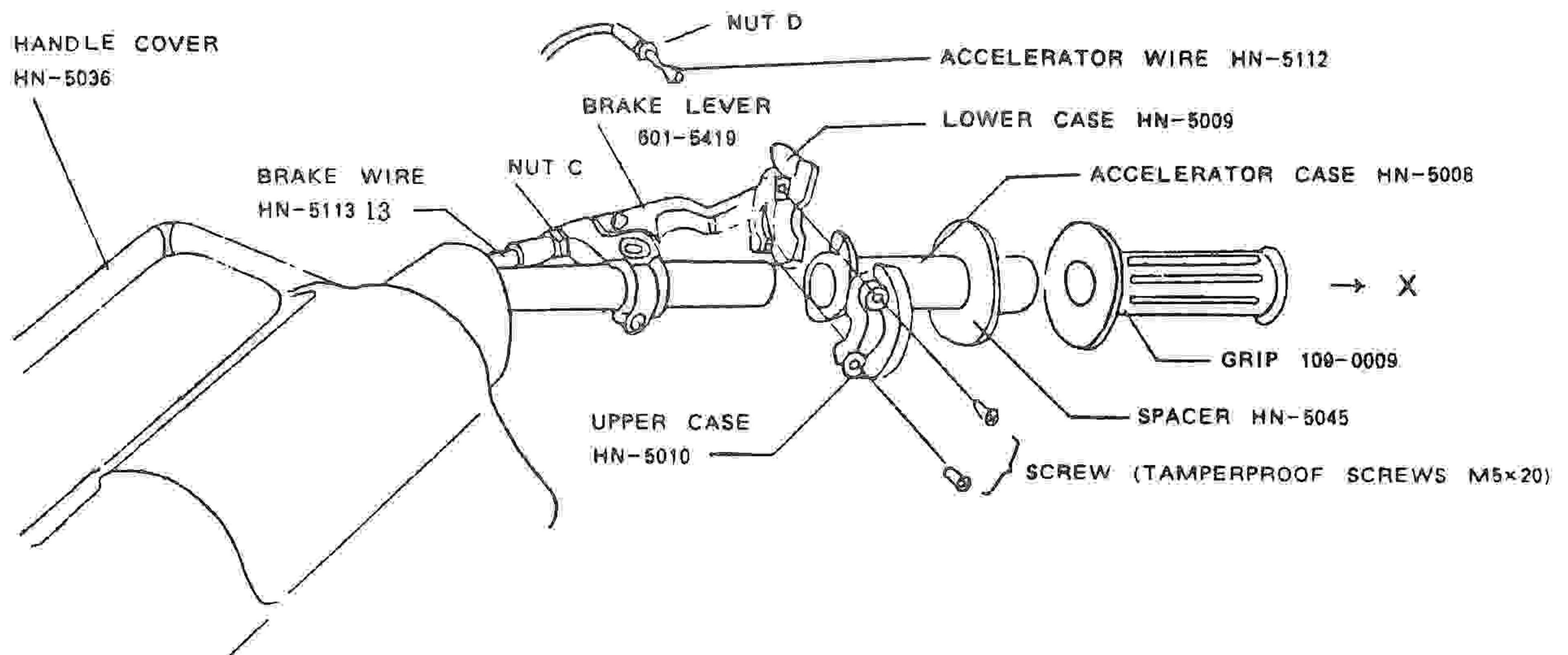
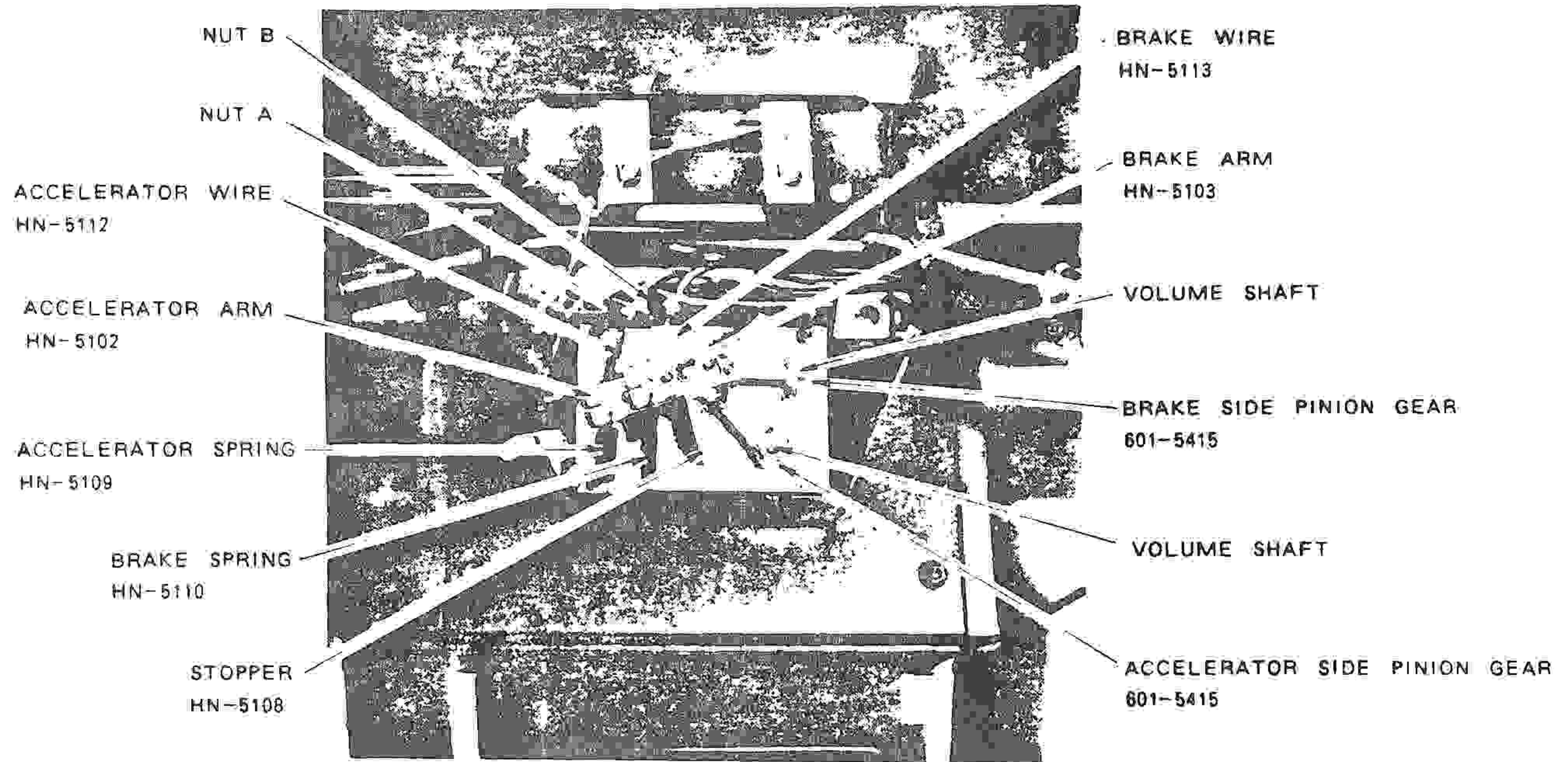

REPLACING THE ACCELERATOR WIRE

- ① Remove the HANDLE COVER (for the removal method, page 20 .)
- ② Take off 2 TAMPERPROOF SCREWS A to disassemble the UPPER CASE and the LOWER CASE from the ACCELERATOR CASE.
- ③ In the above second illustration, the ACCELERATOR WIRE which is attached to the LOWER CASE can be removed by turning the LOWER CASE counterclockwise.
- ④ In the above first illustration, after removing the ACCELERATOR SPRING, release NUT A to take off the ACCELERATOR WIRE.

REPLACING THE BRAKE WIRE

- ① Remove the HANDLE COVER (for the removal method, page 20 .)
- ② Release the BRAKE LEVER'S NUT C to remove the BRAKE WIRE.
- ③ Take off the BRAKE SPRING and NUT B to completely remove the BRAKE WIRE from the HANDLE UNIT.

17. PARTS LIST

① TOP ASSY HANG-ON (HN-00001) (D-1/2)

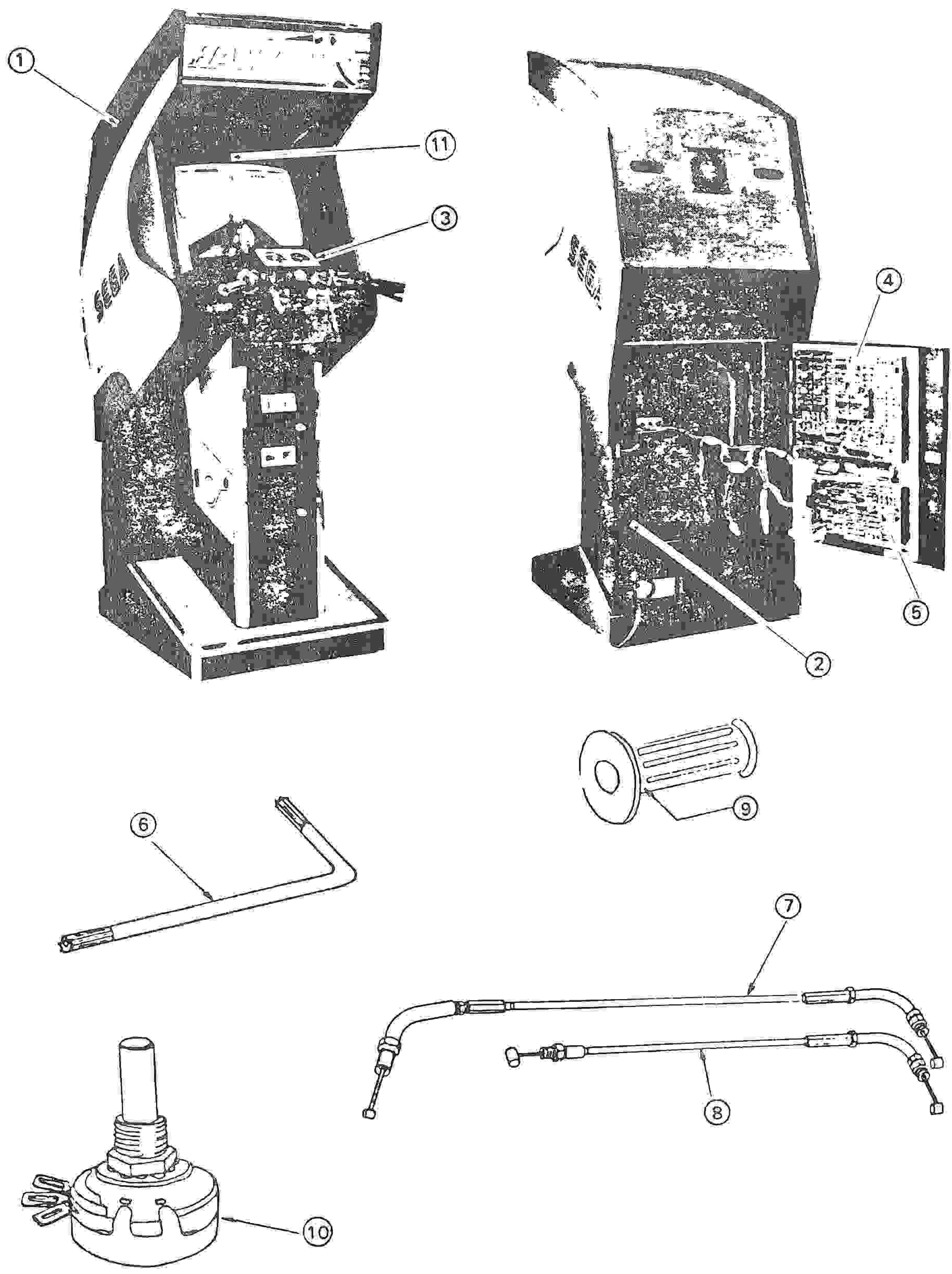

1 TOP ASSY HANG-ON (HN-00001) (D-2/2)

Item No	Part No	Description
1	WIT-10002	Assy Cabinet
2	WIT-40002	Assy Power Supply
3	HN-50001	Assy Handle
4	834-5667-01	Assy Game Board A
5	834-5706-01	Assy Game Board A
6	540-0007	Wrench For Tamperproof Screw M5
	540-0015	Wrench For Tamperproof Screw M6
	540-0009	Wrench For Tamperproof Screw M8
7	HN-5112	Accelerator Wire S
8	HN-5113	Brake Wire S
9	107-0009	Grip Left & Accel
10	220-0094	Volume Control 5K OHM B Type
	220-5130	Volume Control B-5K OHM
11	422-0057	Play Instr Sh
	53870150	Display Manual 20"
12	20-9430-2	Torx Key T-20

② ASSY CABINET (HN-10002) (D-1/3)

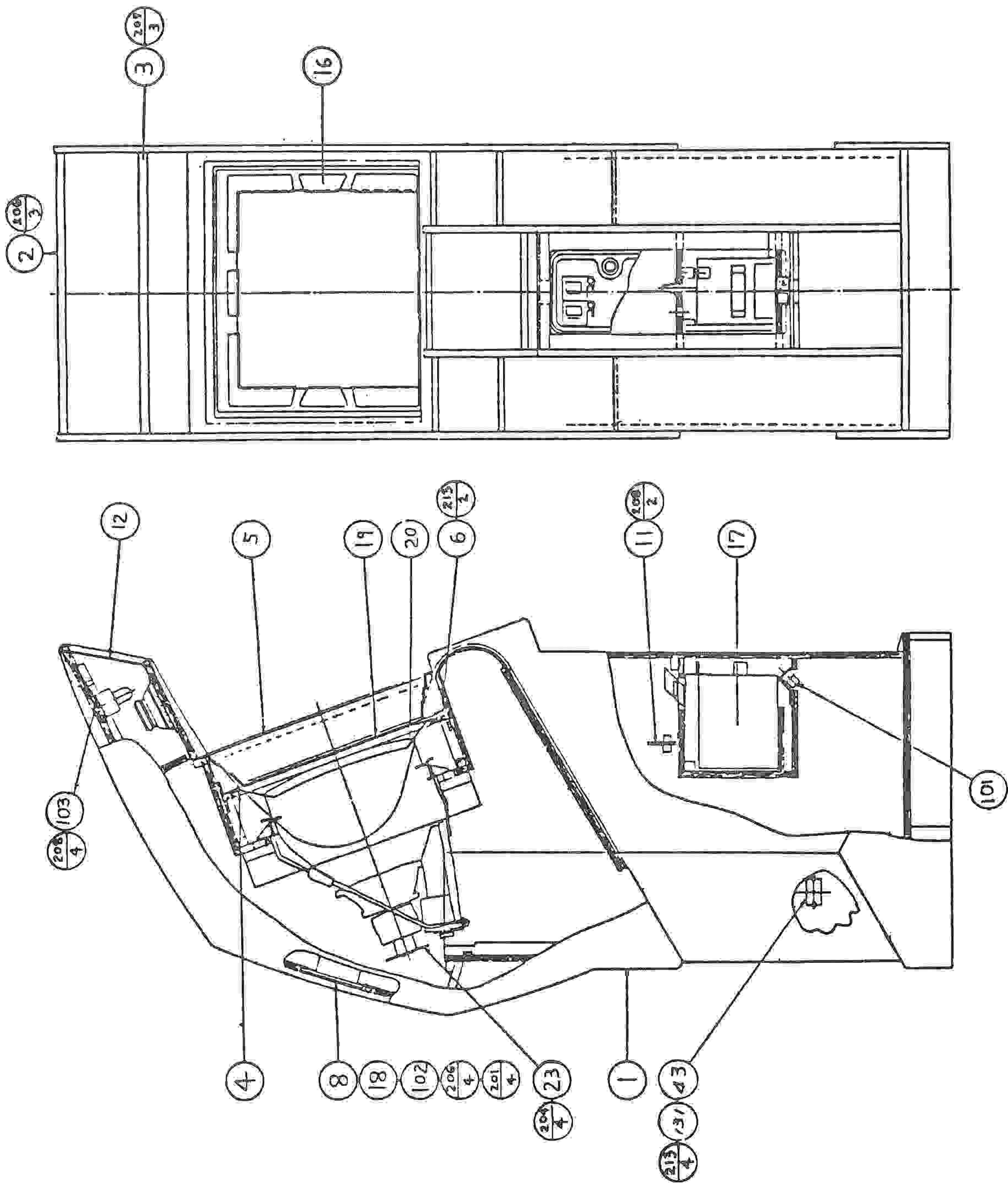

2 ASSY CABINET (HN-10002) (D-2/3)

Item No.	Part No.	Description
1	WIT-1057	Assy Sub-Cab
2	HN-1036	Ornament Frame Top
3	HN-1037	Ornament Frame Lower
4	HN-1038-US	Mask Board
5	HN-1039-US	Window Glass
6	HN-1040-US	Holder Brkt
7		
8	HN-1042-US	Fan Brkt
11	HN-1045	SW Unit
12	HN-1063-US	Billboard Plate
16	HN-1053	Window Mask
17	WIT-1055	Cash Box
18	MO-1051X-US	Guard Plate
19	AB-1151Y-US	TV Mask Gray Smoke
20	AB-1206	TV Mask T8 20
21		
22		
23	5675-10696-00	Assy Clr Displ 20 Type
24		
25		
26	H-209	Wire Harn Fan Motor
27	H-217	Wire Harn FL 15W
28	H-205	Wire Harn Ext AC 115 V
29	H-206	Wire Harn Audio
30	H-208	Wire Harn RGB
31	H-200	Wire Harn Ext 50P
32	H-212	Wire Harn Coin Mtr Ext
33	H-203	Wire Harn Earth
34	H-204	Wire Harn AC IN
35		
36		
37	H-213	Wire Harn Ext 12V
38	H-216	Wire Harn Ext FL
43	01-7228	Brkt Main SW
101	23-1103-00	Mag Cntr 6 Dig DC 5V
102	14-7933	Axial Flow Fan AC 115V 60Hz
103	EE1114	Assy F1 Light 15W 60Hz
104		
105		
106		
107		
108	5791-09111-00	Conn Molex 3P White
109	5792-09110-00	Conn Molex 3R White
110	211-0043	Conn Plug AMP 2P White
111	211-0118	Conn Cap AMP 3P Red
112	211-0086	Conn Plug AMP 3P Brown

2 ASSY CABINET 9HN-10002) (D-2/3)

113	211-0073	Conn Plug AMP 4P White
114	211-0087	Conn Plug AMP 4P Brown
115	211-0102	Conn Plug AMP 4P Yellow
116	211-0044	Conn Cap AMP 2P White
117	211-0080	Conn Cap AMP 2P Brown
118	211-0117	Conn Cap AMP 2P Yellow
119	211-0060	Conn Cap AMP 3P White
120	211-0081	Conn Cap AMP 3P Brown
121	211-0072	Conn Cap AMP 4P White
122	211-0082	Conn Cap AMP 4P Brown
123	211-0084	Conn Cap AMP 9P Brown
124	211-0065	Conn Cap AMP 9P White
125	211-5105	Conn Fem 50P
126	211-5034	Conn Fem 6P
127	211-0041	Conn Pin AMP
128	211-0042	Conn Socket AMP
129	211-0005	Conn Crimp Lock
130	211-5047	Contact (AMP 172656-2)
131	5640-10932-00	SW T DP57 227
132	600-0110	Cable & Plug Assy W/Earth (USA)
201	000-0310-FS	M SCR PH W/FS M3x10
202	000-0414-S	M SCR PH W/S M4x14
203	000-0510-S	M SCR PH W/S M5x10
204	4320-01123-20	BLT 1/4-20 x 1 1/4
206	4108-01098-11B	TMP PRF W SCR #8x11/16
207	010-0406-F	S-TITE SCR PH W/F M4x6
208	4106-01115-06	SMS #6x3/8 PLHWH-A
209	051-0004	FLG Nut M4
212		
213	4608-01081-11	H-F #8x11/16P

③ ASSY SUBCABINET (HN-1057) (D-3/3)

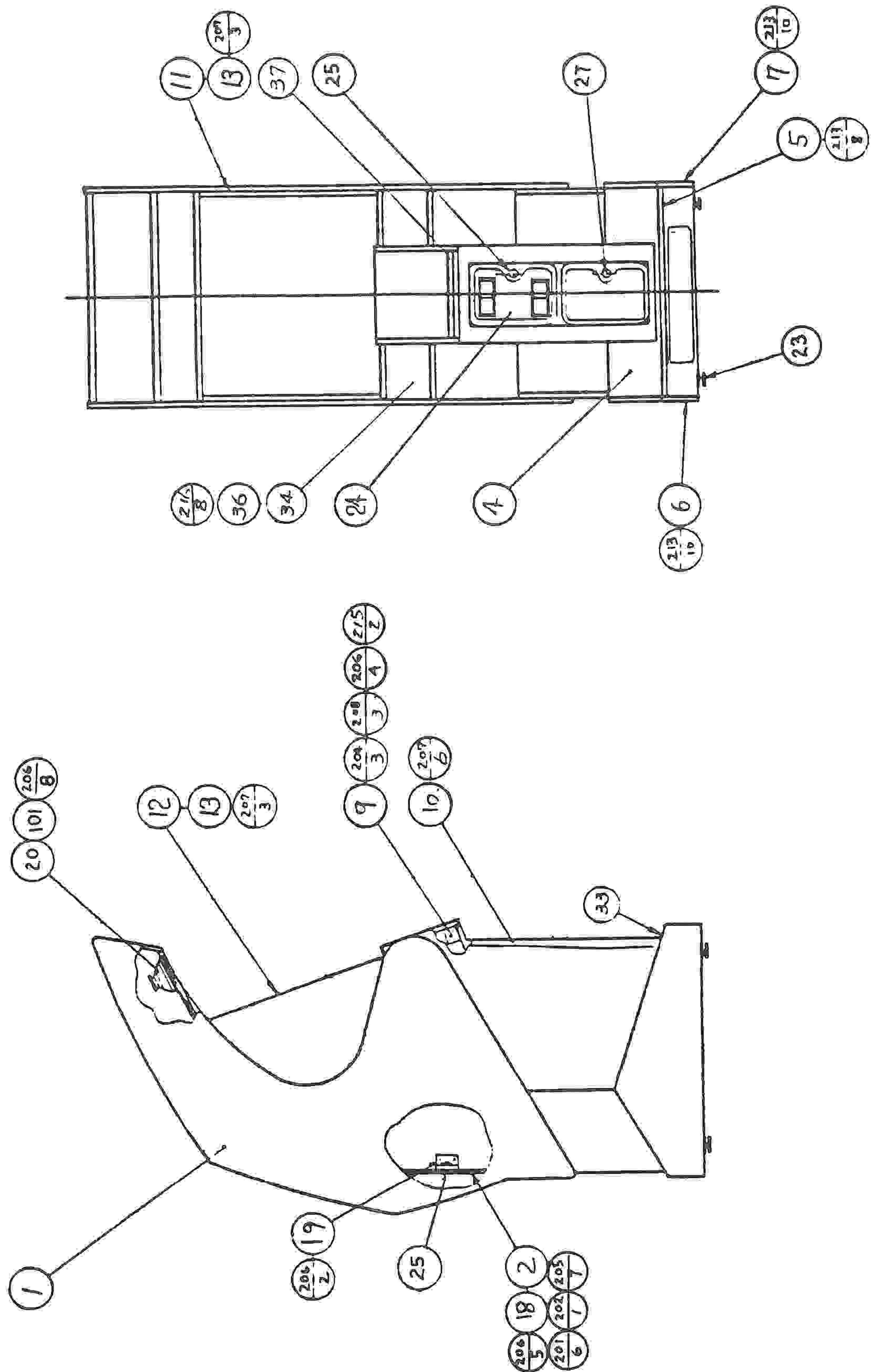

3 ASSY SUBCABINET (HN-1057) (D-2/3)

Item No.	Part No.	Description
1	WIT-1058	Wooden Cabinet
2	WIT-1024	Back Door
3		
4	WIT-1026	Floor Mat
5	HN-1027-US	Corner Protector A
6	HN-1028-US	Corner Protector B
7	HN-1029-US	Corner Protector C
9	HN-1031	Handle Unit Bracket
10	HN-1061	Corner Sash
11	HN-1033	Ornament Protector A
12	HN-1034	Ornament Protector B
13	HN-1035	Spacer
14		
15		
16		
17		
18	01-7224	Rear Door Hinge
19	01-7310	Back Door Striker
20	03-7674	Speaker Grill
21		
22		
23	08-7377	Leg Adjuster
24	10-1120-09	Assy-Coin Chute .25 Twin
25	91-0526-00	Lock w/keys
26		
27	91-0535-00	Lock w/keys
28		
29	H-210	Wire Harn SP Right (MFG)
	H-211	Wire Harn SP Left (MFG)
31		
32		
33	WIT-1060	Floor Mat Front
34	HN-1062	Ornament Plate A
36	HN-1067-US	Holder
37	HN-5035	Hinge 246
38		
39		
101	PF-0036	Speaker 6 inch 8 OHM

ASSY SUBCABINET (HN-1057) (D-2/3)

Item No	Part No	Description
102	211-0094	Conn Plug AMP 2P Red
103	211-0095	Conn Plug AMP 2P Orange
104	211-0073	Conn Plug AMP 4P White
105	211-0041	Conn Pin AMP
106		
107		
201	4320-01123-20	BLT 1/4-20 x 1 1/4
202	4320-01123-36B	BLT 1/4-20 x 2 1/4
204	031-0525-B	CRG BLT-BLK
205	4420-01141-00	Nut 1/4-20 F1
206	4608-01081-7	H-F #8x7/16 P
207	051-0004	FLG Nut M4
208	051-0005	FLG Nut
209		
210		
213	046-0001	SCR Nail TH H STNLS 1.5 x 16
214		
215	4008-01017-08	8-32 x 1/2 RPH-MS
216	4108-01098-11B	W SCR #8 x 11/16

POWER SUPPLY ASSEMBLY

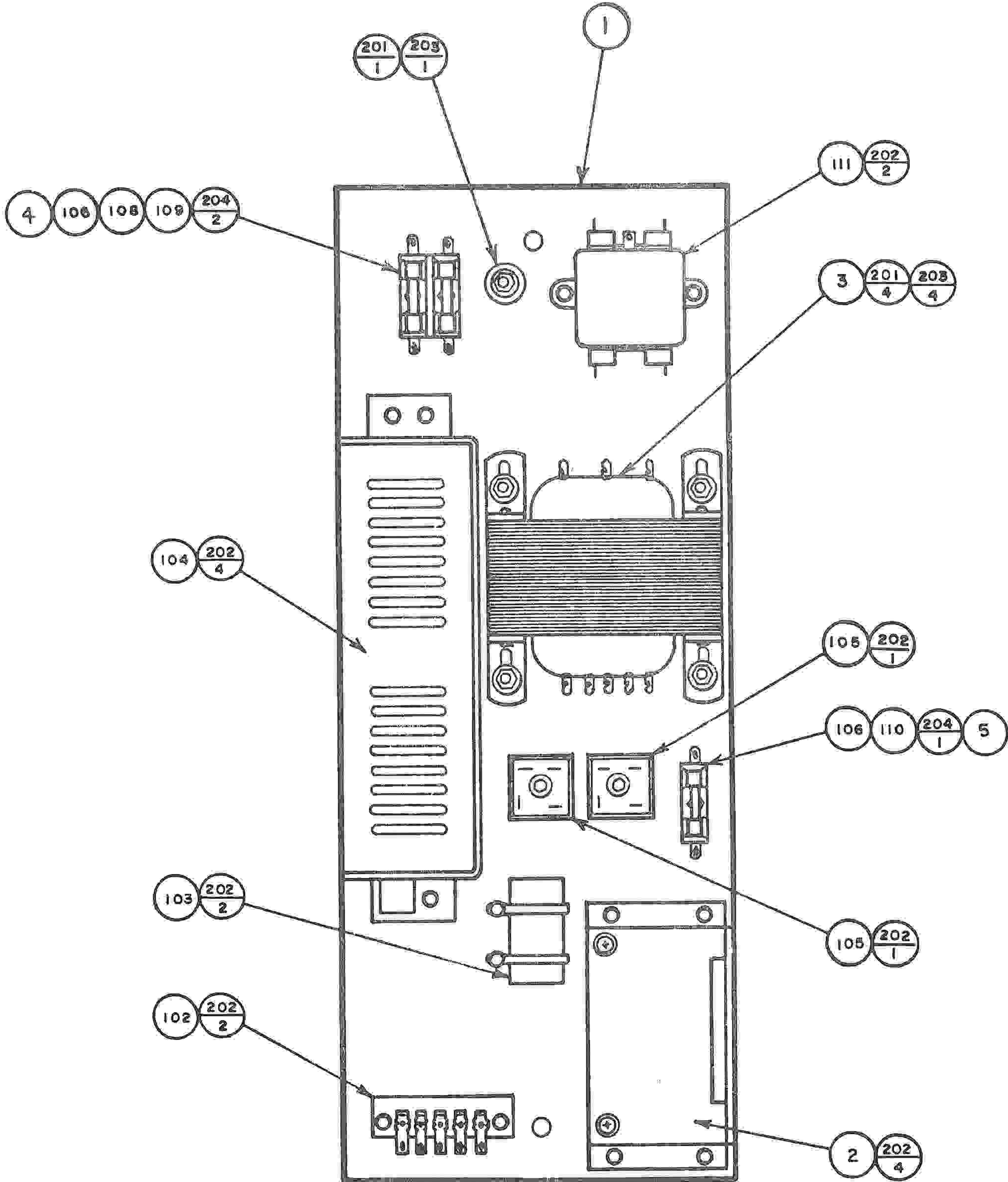

4 ASSY POWER SUPPLY EXPORT (HN-40002) (D-2/2)

Item No	Part No	Description
1	WIT-4004	Base
2	GR-4600	Pwr AMP DC 39V 15W
3	WIT-560-5068	Pwr XFMP 115V 10V 24V 115V
4	WIT-421-6071	Fuse Instr
5	WIT-421-6092	Fuse Instr
6	H-201	5V + GND Cable
7	H-202	5V + GND Cable
8	H-204	A/C Line Filter Cable
9	H-214	A/C Primary Cable
10	H-215	+5V Pwr Supply
102	A-7438-5	Terminal Plate 5P
103	150-0173	Cap E 4700MF 50V C-Type
104	400-5035	SW Reg 90V-240V 5V 10A
105	481-0065	Diode Bridge S2VB10
106	5733-10702-03	Fu Hldr w/cover
107		
108	514-0036	FU 3A 6.4 x 30MM
	514-0036	FU SA 6.4 x 30MM
109	514-0040	FU 4A 6.4 x 30MM
110	514-0034	FU 5A 6.4 x 30MM
111	5102-10310-00	Noise Fltr AC250V
112		
113		
114		
115	5791-09111-00	Conn Plug Molex 3P White
116	211-0080	Conn Cap AMP 3P Brown
117	211-0115	Conn Cap AMP 2P Red
118	211-0116	Conn Cap AMP 2P Orange
119	211-0072	Conn Cap AMP 4P White
120	211-0123	Conn Cap AMP 4P Yellow
121	211-0157	Conn Fem 3P
122	211-0158	Conn Fem 6P
123	211-5101	Conn Fem 10P
124	211-0041	Conn Pin AMP
125	211-0042	Conn Socket AMP
126	211-0005	Conn Crimp Lock
127	211-5047	Contact (AMP 172656-2)
128	211-0044	Conn Cap AMP 2P White
201	4320-01123-20	BLT 1/4 x 20 x 1 1/4
202	4608-01081-11	H-F #8 x 11/16P
203	4420-01141-00	Nut 1/4-20 FL
204	4106-01115-16	SMS #6 x 1 PL-H

⑤ ASSY HANDLE (HN-50001) (D-1/3)

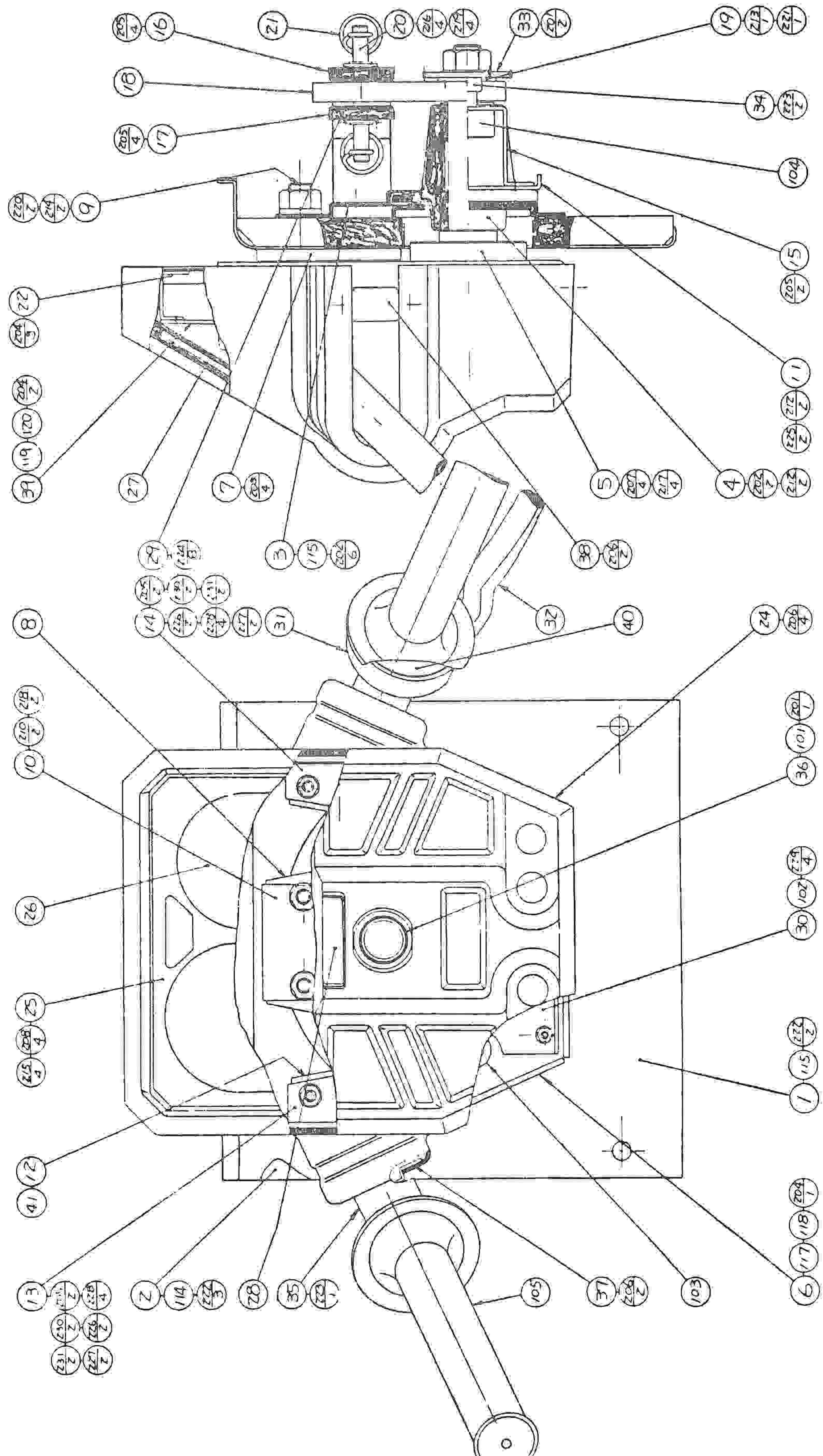

⑤ ASSY HANDLE (HN-50001) (D-2/3)

ITEM NO.	PART NO.	DESCRIPTION
1	HN-5013X	FRONT PANEL
2	HN-5014	BASE
3	HN-5015	HANDLE BRACKET
4	TB-2004X	HOUSING
5	HN-5017	HANDLE SHAFT
6	HN-5018X	HANDLE BASE
7	HN-5019	SLIDE PLATE A
8	HN-5020	SLIDE PLATE B
9	HN-5021	SLIDE SHAFT
10	HN-5022	SLIDE HOLDER
11	HN-5023	VR BRACKET BASE
12	HN-5024X	BUMPER
13	HN-5025X	BUMPER HOLDER A
14	HN-5026X	BUMPER HOLDER B
15	HN-5027	VR BRACKET
16	HN-5028	GUIDE BRACKET UPPER
17	HN-5029	GUIDE BRACKET LOWER
18	HN-5030	CAM
19	HN-5031	GEAR BRACKET
20	HN-5032X	SHAFT
21	HN-5033X	EXTENSION SPRING
22	HN-5034	REAR LID
24	HN-5036	MECHANISM COVER
25	HN-5037	PANEL
26	HN-5038	METER PLATE F
27	HN-5039	METER PLATE R
28	421-6103	STICKER START
29	HN-5040	GUIDE PLATE
30	HN-5111	ASSY CONTROL
	SGB-3636-13	WIRE HARN VR
	SGB-3636-15	WIRE HARN START
	SGB-3636-16	WIRE HARN EXT CONT
31	601-5418	ASSY ACCELERATOR CASE
32	601-5419	ASSY LEVER
33	601-5423	GEAR 1/6
34	601-5424	GEAR 30
	SGB-3636-21	WIRE HARN LAMP
35	HN-5041	SPACER
36	HN-5042	STOPPER RING
37	HN-5043X	COVER A
38	HN-5044X	COVER B
39	TB-2007	LAMP HOLDER BOARD
40	HN-5045	SPACER
41	HN-5046	SPACER TUBE
101	509-5050	PUSH BUTTON SWITCH 1T YELLOW W/LAMP
102	310-5009	INST SPIRAL TUBE ID ϕ 9
103	280-5066	RUBBER GROMMET
104	220-0094	VOL CONT 5K Ω B TYPE
	220-5130	VOL CONT B-5K OHM
105	107-0009	GRIP LEFT & ACCELERATOR

⑤ ASSY HANDLE (HN-50001) (D-3/3)

ITEM NO.	PART NO.	DESCRIPTION
106	211-0059	CONN PLUG AMP 3P WHITE
107	211-0101	CONN PLUG AMP 4P ORANGE
108	211-0064	CONN PLUG AMP 9P WHITE
109	211-0121	CONN CAP AMP 4P RED
110	211-0122	CONN CAP AMP 4P ORANGE
111	211-0041	CONN PIN AMP
112	211-0042	CONN SOCKET AMP
113	280-0472	FASTON RCPT 110
114	280-0419	HARNESS LUG
115	601-5003	FREE BUSH
116	211-0043	CONN PLUG AMP 2P WHITE
117	280-0132	CLAMP CORD PLASTIC ID 10mm
118	280-5008	CORD CLAMP ϕ 15
119	214-0081	WEDGE BASE SOCKET ASSY
120	390-0116	LAMP WEDGE BASE TYPE 14V 0.24A
201	000-0406-S	M SCR PH M4x6
202	000-0514	M SCR PH W/S M5x14
203	006-3520	W SCR FH 3.5x20
204	010-0308-F	S-TITE SCR PH W/F M3x8
205	010-0408-F	S-TITE SCR PH W/F M4x8
206	008-0510	TMP PRF SCR TH M5x10
207	030-0612	HEX BLT M6x12
208	050-0004	HEX NUT M4
210	050-0008	HEX NUT M8
212	051-0005	FLG NUT M5
213	059-0016	HEX NUT M14
214	059-0017	HEX NUT M12 P=1.75
215	060-0004	FLT WSHR M4
216	060-0008	FLT WSHR M8
217	061-0006	SPR WSHR M6
218	061-0008	SPR WSHR M8
219	065-0006	E RING 6mm
220	069-0016	SPR WSHR BLK M12
221	069-0019	SPR WSHR M14
222	005-3113-F	W SCR RH W/F 3.1x13
223	028-0014	SET SCR HEX SKT CP UNBR M4x4
224	001-0410	M SCR FH M4x10
225	000-0516-S	M SCR PH W/S M5x16
226	001-0512	M SCR FH M5x12
227	029-0043	M SCR FH M6x35
228	060-0006	FLT WASHER M6
229	000-0410-FS	M SCREW PH W/FS M4x10
230	054-0005	U NUT M5
231	054-0006	U NUT M6

⑥ ASSY CONTROL (HN-5111) (D-1/2)

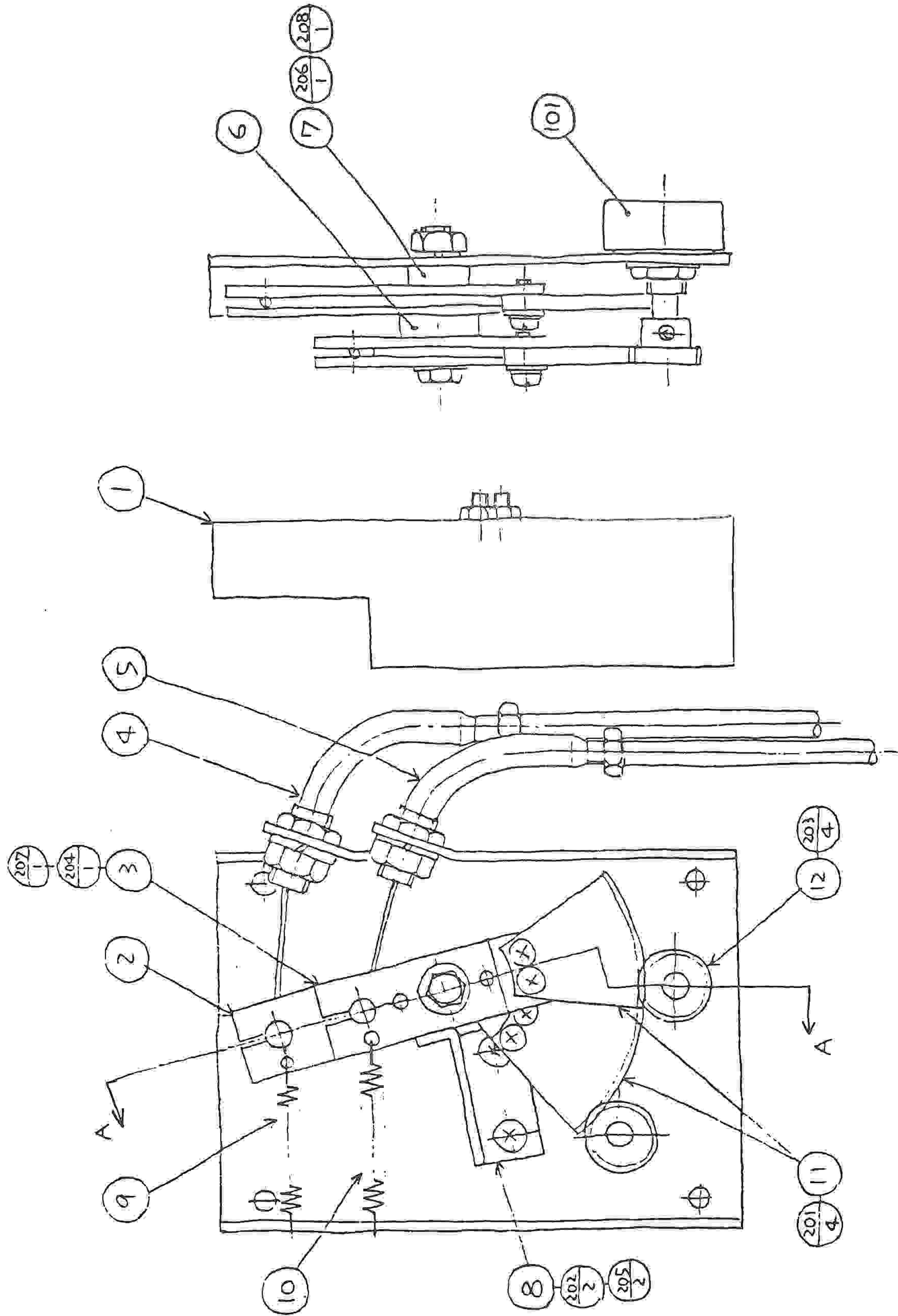

⑥ ASSY CONTROL (HN-5111) (D-2/2)

ITEM NO.	PART NO.	DESCRIPTION
1	HN-5101	BRACKET
2	HN-5102	LEVER LONG
3	HN-5103	LEVER SHORT
4	HN-5112	ACCELERATOR WIRE S
5	HN-5113	BRAKE WIRE S
6	HN-5106	SPACER
7	HN-5107	STUD
8	HN-5108	STOPPER
9	HN-5109	EXT SPRING ACCEL
10	HN-5110	EXT SPRING BRAKE
11	601-5251	GEAR 1/8
12	601-5415	GEAR 20
	SGB-3636-14	WIRE HARN CONT
101	220-0094	VOL CONT 5KΩ B TYPE
	220-5130	VOL CONT B-5K OHM
102	211-0100	CONN PLUG 4P RED
103	211-0041	CONN PIN AMP
201	000-0408-FS	M SCR PH W/FS M4×8
202	001-0410	M SCR FH M4×10
203	028-0014	SET SCR HEX SKT CP UNBR M4×4
204	030-0508	HEX BLT M5×8
205	050-0004	HEX NUT M4
206	050-0006	HEX NUT M6
207	060-0005	FLT WSHR M5
208	061-0006	SPR WSHR M6

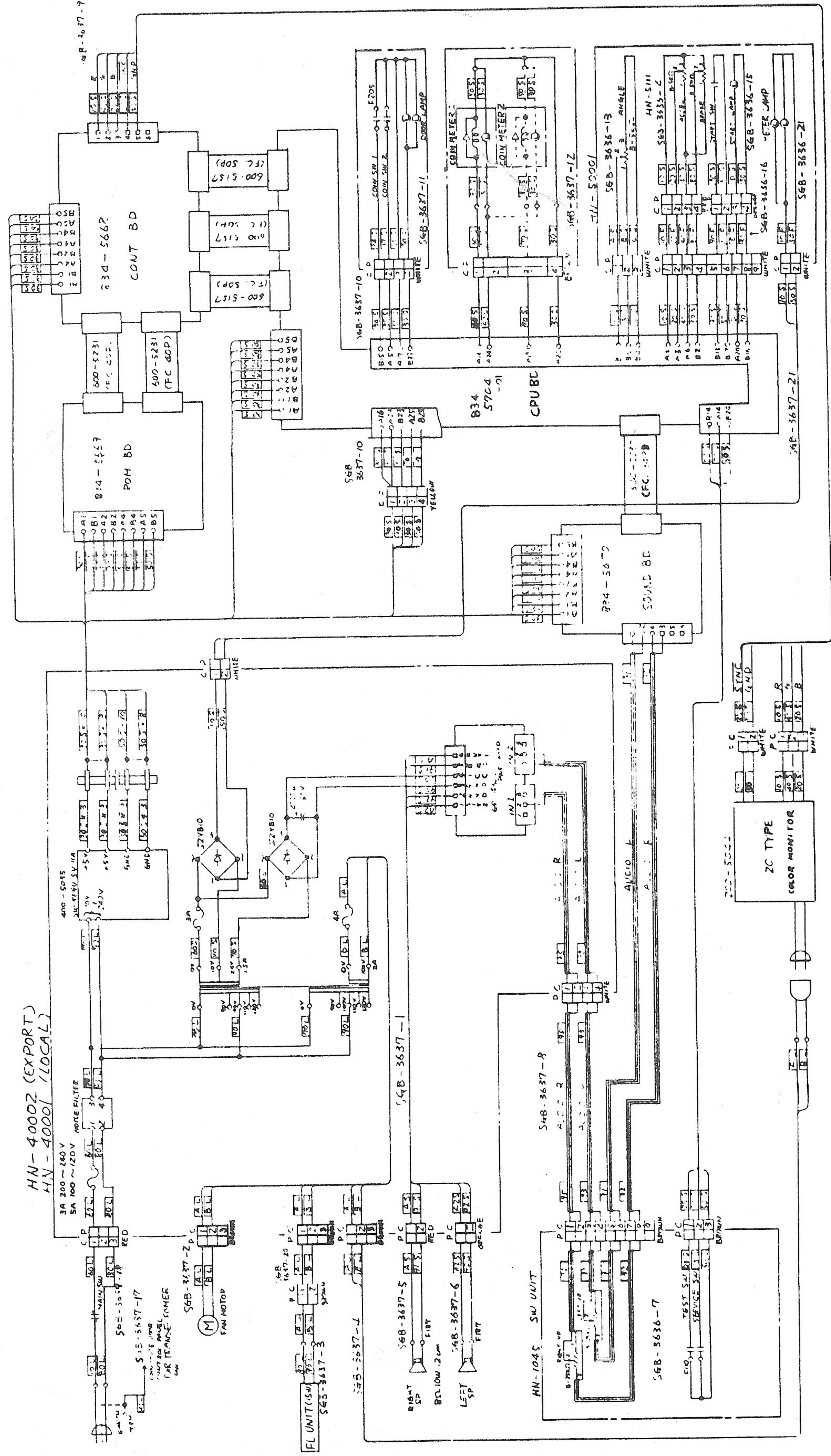

18. SCHEMATIC DIAGRAM

SEGA ENTERPRISES, LTD.
No. 2-12 Haneda 1-Chome
Ohta-ku, Tokyo, Japan 144
Tel. (03) 742-3171

© SEGA 1985

SCANS BY CLOGGEDMIND
PRINTED IN JAPAN