



COPYRIGHT 1984

*Williams*®   
ELECTRONICS, INC.



INSTRUCTION MANUAL

16-3028-101  
October, 1984

For Service...

Call your authorized  
WILLIAMS distributor

WILLIAMS ELECTRONICS, INC.  
3401 N. California Ave.  
Chicago, Il 60618

## CONTENTS

Warnings and Notices.....	1 & 15
Parts List.....	2
Cabinet .....	3
CRT Decals and Marquee.....	3
Decal Layout.....	4
Control Panel.....	7
Control-Panel Decal Layout.....	5
Joystick Assembly.....	6
Wiring Procedures.....	7
Troubleshooting.....	8
Wiring Harness.....	9
Control Panel Wiring.....	10
Dip Switch Adjustments.....	11 & 12
Game Description.....	13
Game Operation.....	14
Control-Panel Template.....	16

IMPORTANT  
F.C.C. WARNING

"THIS KIT IS INTENDED FOR USE ONLY ON COIN OPERATED VIDEO GAMES MANUFACTURED AFTER JANUARY 1, 1983, WHICH HAVE BEEN VERIFIED FOR COMPLIANCE WITH THE REQUIREMENTS IN PART 15 OF FCC RULES FOR CLASS A COMPUTING DEVICE. IMPROPER CONNECTION OF THIS KIT OR CONNECTION TO ANY OTHER COIN OPERATED VIDEO GAME NOT SO MANUFACTURED OR VERIFIED FOR COMPLIANCE TO RADIO AND TV RECEPTION REQUIRING THE OPERATOR TO TAKE WHATEVER STEPS ARE NECESSARY TO CORRECT THE INTERFERENCE. WILLIAMS ELECTRONICS, INC. TAKES NO RESPONSIBILITY FOR KITS IMPROPERLY CONNECTED AND THOSE CONNECTED TO GAMES FOR WHICH USE IS NOT INTENDED."

NOTICE: MONITOR

1. This kit is not intended for use with X-Y monitors. Suitable monitors are horizontal raster-type with inputs for red, green and blue video as well as negative sync. (These inputs should be compatible with TTL logic levels.)
2. This game's horizontal sweep lasts 50 microseconds. This time constant may not be compatible with monitors designed to display a 40-microsecond video signal. The affect would be a horizontal overscan and loss of partial video display on the left and right sides of the screen. Consult your monitor's manufacturer on how to convert your monitor, or use a 50-microsecond monitor.

NOTICE: POWER SUPPLY

Be sure the power supply from your old game is capable of +5VDC at 5A and +12VDC at 1A. These operating voltages are necessary for your kit.

If power supply is purchased, it must be F.C.C. approved.

NOTICE

Parts salvaged from an old game are required to complete your kit. These salvaged parts MUST operate perfectly, or the converted game cannot perform properly or safely. ALWAYS repair circuitboard malfunctions and cabinet damage before conversion is attempted.

NOTICE

Make sure you clean and lubricate your old coin mechanisms. Servicing them is crucial to this game's earnings and operation!

CONVERSION INSTRUCTIONS

NOTICE

Use this checklist to be sure your kit is complete.

PARTS PROVIDED

<input type="checkbox"/>	control-panel overlay	31-1317-3028	(1)
<input type="checkbox"/>	CRT-glass decal	31-1319-3028	(2)
<input type="checkbox"/>	easel	08-7434	(1)
<input type="checkbox"/>	FCC cage with CPU board	D-10582	(1)
<input type="checkbox"/>	instruction card	16-3028-1	(2)
<input type="checkbox"/>	joystick assembly	20-9319	(1)
<input type="checkbox"/>	marquee decal	31-1318-3028	(1)
<input type="checkbox"/>	miscellaneous control panel decals	31-1324-3028	(1 set)
<input type="checkbox"/>	#6x3/8" phil. hd. Sht. Metal Screw	4106-01004-06	(4)
<input type="checkbox"/>	nameplate sticker	31-1321-3028	(2)
<input type="checkbox"/>	player-button assembly	C-9214-9	(2)
<input type="checkbox"/>	side decal	31-1320-3028	(2)
<input type="checkbox"/>	wiring harness	H-10583	(1)

RECOMMENDED TOOLS AND SUPPLIES

- black or red semi-gloss paint
- electric drill
- electric screwdriver
  
- grease pencil or marker
- hex driver
- 180-grit sandpaper (sander)
  
- Phillips screwdriver
- pliers
- razor knife
  
- soldering iron and solder
- wire cutters

A. Cabinet Modifications

- [ ] 1. First inspect your old cabinet. Remove foreign objects and fill in gouges with quick-hardening wood putty. Sand the cabinet and wipe it clean.
- [ ] 2. Refer to the decal layout sheet. If the kit decal doesn't cover the old graphics, repaint your cabinet with black or red semi-gloss paint. Games with woodgrain sides: Remove the old decals and clean the game so that no residue of old glue is left behind.
- [ ] 3. SIDE DECALS: Make a line roughly at the top of the old graphic. Lightly moisten the cabinet with soapy water or glass cleaner. Apply the decal starting at the top and work down. After the decal is in place, use a piece of the foam packaging as a squeegee and smooth the sticker down. Use a razor blade or needle to pop air bubbles in the decals. Allow 12 hours for your sticker's adhesive to set.
- [ ] 4. Position the FCC sticker near the power cord.
- [ ] 5. Inspect your CRT glass for cigarette burns and scratches. If the CRT glass is unacceptable, replace it with clear or smoked acrylic. Place one sticker on the right and one on the left side. Be careful not to cover the monitor.
- [ ] 6. Place your instruction card below the WILLIAMS circle on either the right or left side.

B. Marquee Modifications

- [ ] 7. MARQUEE OVERLAY. We recommend using a new piece of clear acrylic in place of your old marquee. With the overlay on top of an old marquee, the marquee may not transmit light as well as it did with the old game.
- [ ] 8. Refer to the decal layout. Remove the old marquee. Lift the backing from the left edge of the marquee overlay. Letting the overlay hang over the edge of the glass, stick down one edge on the new glass (or old marquee glass). Check to see that the game name is centered and that it's square with the top of the glass.
- [ ] 9. With one hand, peel the backing a few inches at a time. Rub down the overlay with your other hand. Where each corner of the overlay hangs over the glass, cut a 45-degree diagonal with a razor knife. Bend the marquee overlay behind the glass. Replace the marquee in the game. Your new marquee won't have any edges to be peeled off.
- [ ] 10. For your protection, place your official WILLIAMS SURVIVAL KIT sticker at the top-center corner of your marquee.
- [ ] 11. If old graphics show through your marquee overlay, disconnect the marquee light.

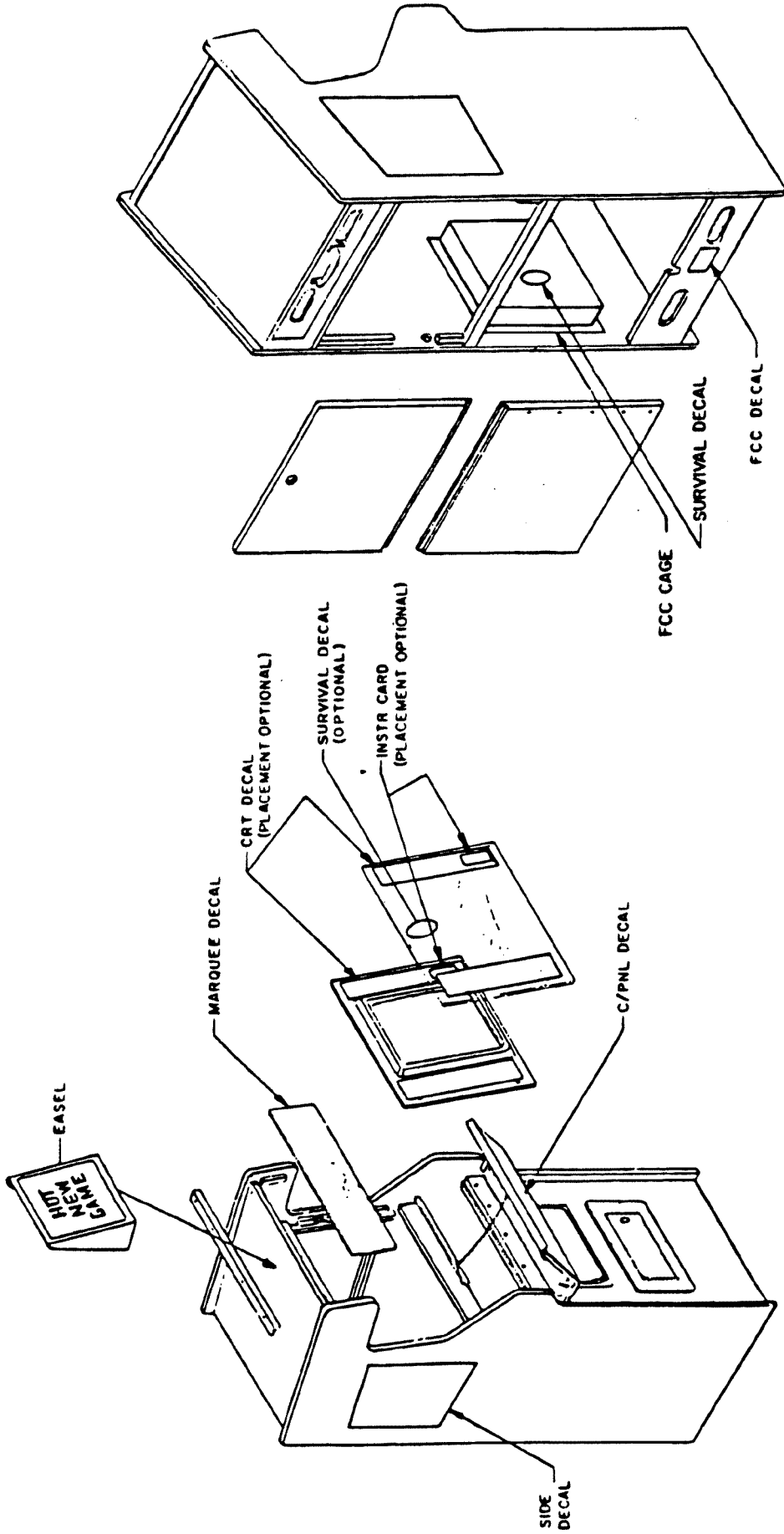

DECAL LOCATIONS

### C. Control-Panel Modifications

- [ ] 12. Remove control-panel buttons or joysticks. Clean and sand any imperfections on the old vinyl material, or remove old vinyl.
- [ ] 13. Place the control-panel template on the control panel and use it to help you design your control-panel layout.
- [ ] 14. Leave your 1 and 2-player START button holes where they are. Drill holes as needed for the joystick and other buttons. Plug old holes with wood blocks, putty, cardboard or epoxy. File the new holes smooth.
- [ ] 15. Position the control-panel overlay. The simulated-chrome strip should run down the middle where your buttons will be mounted. The WILLIAMS "W" should be directly in the center of your control panel where your joystick is mounted. Remove the backing from the top of the overlay. Carefully place the overlay on top of the old control panel. Try not to get any bubbles under the vinyl.
- [ ] 16. After the overlay is on securely, use a razor knife to cut holes for your buttons and joystick. Place your components on the control panel and tighten them down. Player-1 and Player-2 START stickers go next to the appropriate buttons. A joystick-direction decal goes around your joystick opening, (see page 6 for Joystick Assem. instructions). Position LASER, ENERGY, JUMP and TRANSFORM stickers according to the template.
- [ ] 17. If your control panel is too thick for the kit's buttons, remove the switches from the buttons and shim them with the enclosed spacers.

### D. Installing Interboard Wiring

- [ ] 18. Disconnect the old wiring-harness from the CPU board. Using the schematic drawings from your old game, carefully note the function of each wire. Label the wires if this helps.
- [ ] 19. Carefully remove the circuitboards and the metal circuitboard panel. Set these aside for later use. Keep the transformer chassis in the game.
- [ ] 20. Leaving several inches of wire at each connector, cut the wires near the game's coin door, monitor, player panel, power supply and speaker. DON'T CUT the other side of these same wires (that is, at the CPU-board end).
- [ ] 21. Following the schematic drawings for your kit, solder the coin-door, monitor, player panel, power-supply and speaker wires to the new CPU-board harness. Using electrical tape, be sure to insulate all splices.
- [ ] 22. If your game has series-pass transistors for the power supply on a separate heatsink, remount the metal heatsink beside the power-supply board.
- [ ] 23. Check and clean the input jack on the power-supply board. Replace any burned or damaged pins.

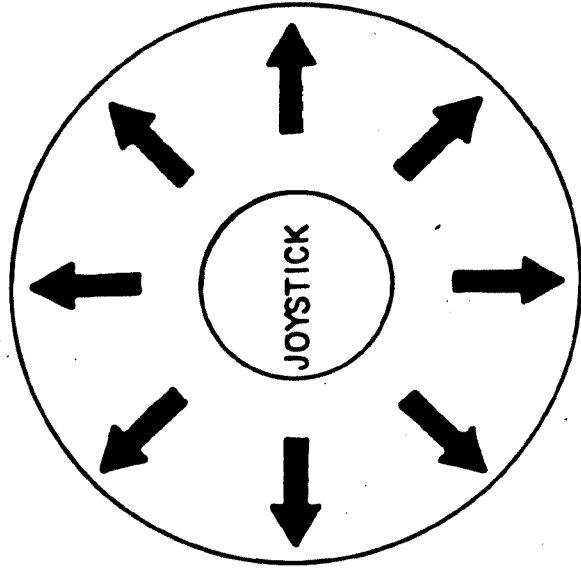

LASER

LASER  
BUTTON

HOLD FOR  
ENERGY

JUMP

JUMP  
BUTTON

HOLD TO  
TRANSFORM

CONTROL PANEL DECAL LAYOUT



### JOYSTICK ASSEMBLIES

1. Refer to FIG. 1 before starting installation.
2. For normal replacement of Ball Handle, Spring and/or Switch Actuator, disregard Steps 3, 4 and 5 below.

#### INSTALLATION INSTRUCTIONS

1. From inside of game, remove E-Ring from Ball Handle Shaft.
2. Pull Ball Handle out of Joystick Assembly and remove Switch Actuator and Spring from inside of game.
3. Remove Joystick Assembly from Control Panel of game.
4. Replace 2" washer.
5. Fasten Joystick Assembly to Control Panel of game.
6. Insert new Ball Handle thru Control Panel and Joystick Assembly.
7. From inside of game, push Spring and appropriate Switch Actuator over end of Ball Handle Shaft and secure with E-Ring.

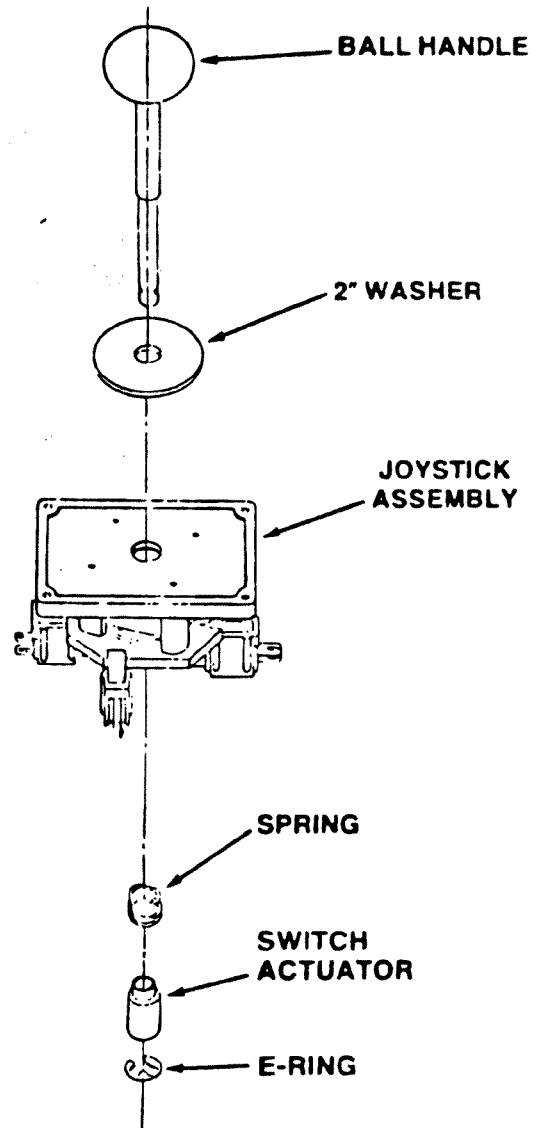

FIGURE 1

E. Installing the FCC Cage

- [ ] 24. Using the screws (supplied), mount the FCC cage on one of the inside walls of the game. While installing the FCC cage, DO NOT OPEN IT.
  
- [ ] 25. Remove one of the screws holding the transformer, the power supply board and the FCC cage. Replacing these screws, secure a ground braid or wire between each part.
  
- [ ] 26. Plug the new wiring harness into the new CPU board. Support the harness as necessary with plastic wireguides.

TROUBLESHOOTING

Custom-LSI Test

With the game off, hold the PLAYER-1 switch down. Now turn the power on. The system will enter the custom-LSI test.

PASS 201 -- Normal LSI.

ERROR 201 -- Defective LSI. Replace LSI (6J).

With the game off, hold the PLAYER-2 switch down. Now turn the power on. The system will display a 201 ERROR message on the CRT.

If any switch is stuck when the power is first switched on, the system will display a test message and lock up. Locate and clear stuck switches.

SYMPTOM	CHECK
NO MOTION	Main-CPU 68B09 (3D), program-memory 27128 (5B or 5C), system-RAM 6116 (3A or 3B), address-decoder 7051 (5B)
NO SOUND	Sound CPU 6809 (3J0 and surroundings or output power-amp 1182H3
BACKGROUND AND CHARACTER DEFFECTIVE	V-RAM 6116 (7N), Character ROM 2764 (7R) and surroundings
UNSTABLE PICTURE DISPLAY	<u>Horizontal</u> - Horizontal oscillator LS93 (2C0, LS74 (6D), LS161 (7B or 8B) <u>Vertical</u> - Vertical oscillator LS74 (6D), LS161 (6F, 7F)
ODD COLORS	Fuse ROM 7052 (10A, 10B, 10C), output LS174 (9B, 9C) and color-output resistors (to monitor)
NO STARS PRODUCED	Character ROM 2764 (11J) and surroundings

PCB COMPONENT SIDE



JACK

P.C.B. PLUG

HOUSING: 5790-09769-00

PIN: 5822-09770-00

KEY: 5823-10763-00

WIRE GAUGE	FUNCTION	WIRE COLOR	PIN	PIN	WIRE COLOR	FUNCTION	WIRE GAUGE
18	GND	BLK	A	1	BLK	GND	18
18	GND	BLK	B	2	BLK	GND	18
18	GND	BLK	C	3	SHIELD WIRE	**GND	24
18	GND	BLK	D	4	RED BLK	SPEAKER+	22
18	+5VDC	GRY	E	5	GRY	+5VDC	18
		KEY	F	6	KEY		
22	2P START	YEL GRN	H	7	YEL BLU	1P START	22
		N/C	J	8	WHT BLU	COIN SWITCH	22
		N/C	K	9		N/C	
18	+12VDC	GRY YEL	L	10	GRY YEL	+12VDC	18
22	2P UP COCKTAIL	RED BRN	M	11	ORG BRN	1P UP	22
22	2P DOWN "	RED	N	12	ORG RED	1P DOWN	22
22	2P RIGHT "	RED ORG	P	13	ORG	1P RIGHT	22
22	2P LEFT "	RED YEL	R	14	ORG YEL	1P LEFT	22
22	2P FIRE "	RED GRN	S	15	ORG GRN	1P JUMP	22
22	2P JUMP COCKTAIL	RED BLU	T	16	ORG BLU	1P FIRE	22
24	**VIDEO BLU	BRN	U	17	RED	**VIDEO RED	24
24	**VIDEO SYNC	WHT	V	18	GRN	**VIDEO GRN	24

NOTE \*\*FROM SHIELDED CABLE

NOTE:  
LOOKING FROM INSIDE OF  
CONTROL PANEL.

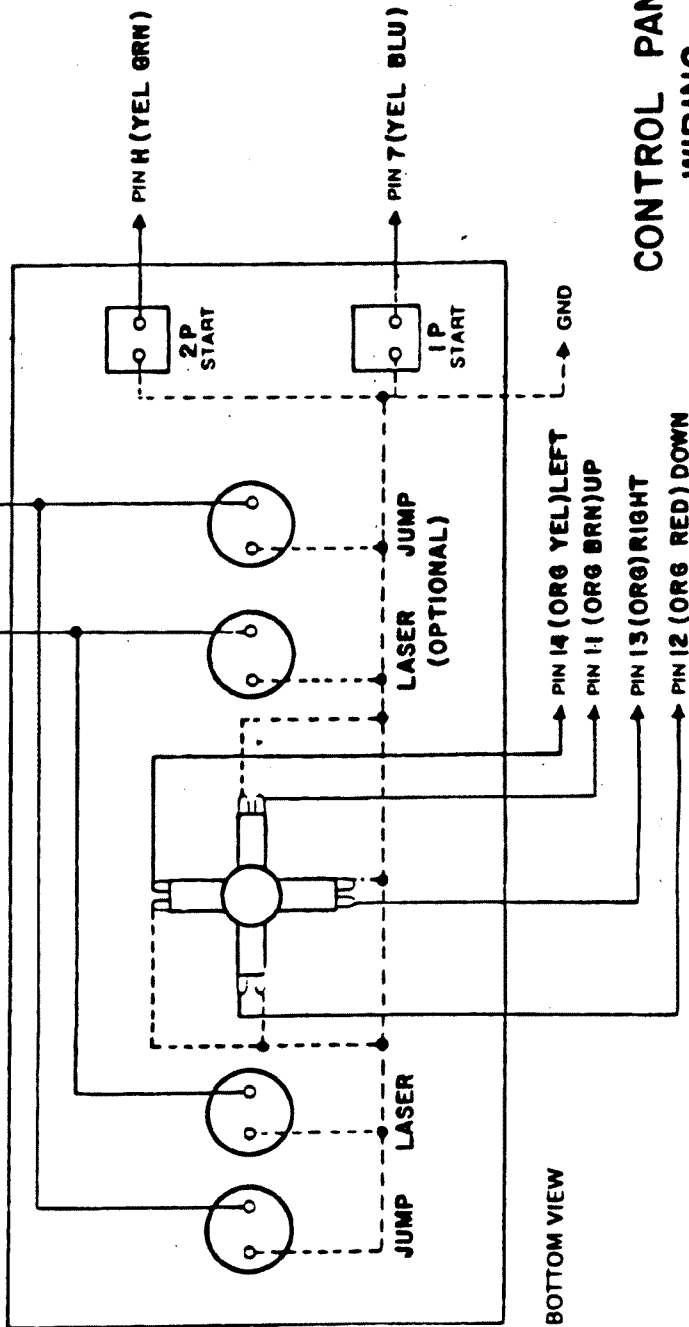

**CONTROL PANEL  
WIRING**

**REV. 1**

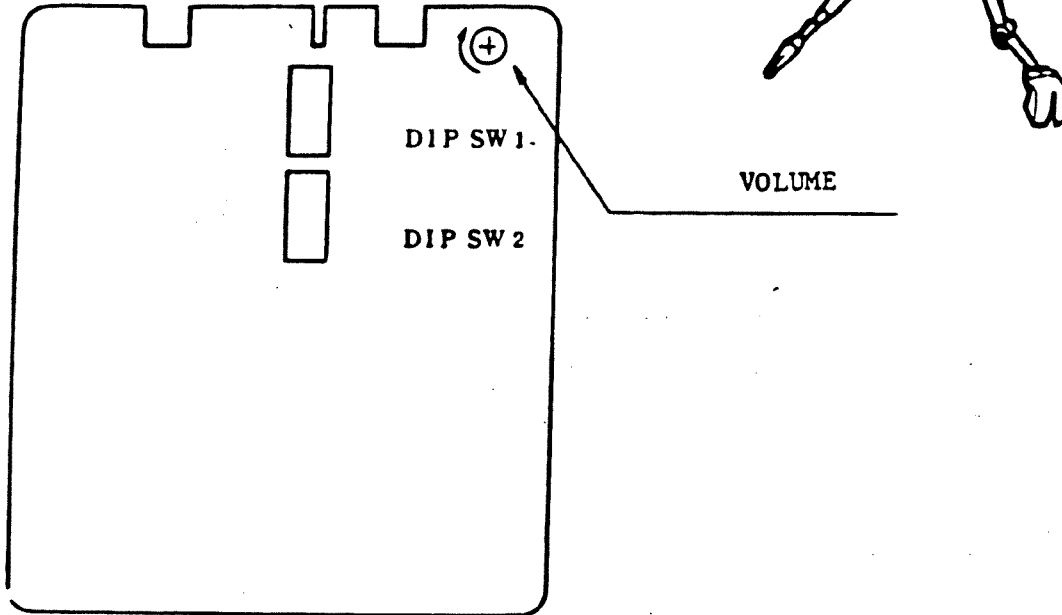

#### ADJUSTMENTS

1. Game adjustments are made using switches contained in DIP Switch 1 and 2 on the CPU Board. Using a pen or small screwdriver, move switches to desired positions of OFF or ON. After making adjustments turn your game on and off to reset the CPU.
2. Volume adjustments are made by rotating the knob indicated in the above drawing.

NOTE: When making adjustments you need not open the FCC Cage. These are slots provided to make the required adjustments.

**DIP SWITCH 1**

	1	2	3	4	5	6	7	8
NUMBER OF PLAYERS 3	ON	ON						
4	OFF	ON						
5	ON	OFF						
FREE PLAY	OFF	OFF						
BONUS PLAYER 30000 pts.			OFF	OFF				
40000 pts.			ON	OFF				
70000 pts.			OFF	ON				
100000 pts.			ON	ON				
ATTRACT SOUND WITHOUT						ON		
WITH	FACTORY					OFF		
TABLE TYPE							ON	
UP RIGHT TYPE							OFF	
SCREEN INVERSION								*

Adjust screen direction by changing switch, over ON or OFF.

**DIP SWITCH 2**

	1	2	3	4	5	6	7	8.
1 COIN 1 PLAY	ON	ON	ON					
" 2 PLAY	ON	OFF	ON					
" 3 PLAY	ON	ON	OFF					
" 4 PLAY.	ON	OFF	OFF					
2 COIN 1 PLAY	OFF	ON	ON					
3 COIN 1 PLAY	OFF	OFF	ON					
4 COIN 1 PLAY	OFF	ON	OFF					
5 COIN 1 PLAY	OFF	OFF	OFF					
SKILL EASY				ON	ON			
FACTORY 1				ON	OFF			
2				OFF	ON			
3 DIFFICULT				OFF	OFF			

**IMPORTANT- BEFORE PLACING THE GAME ON LOCATION MAKE SURE THAT THE DIP SWITCHES ARE AT FACTORY POSITIONS !**

GAME PLAY

THE PLAYER CONTROLS THE JOYSTICK and FIRE button to compete in a marathon shootem-up across air, sea and land..plus outer space!

AEROBOTO can be either a MOBILE ROBOT or an AERO-FIGHTER at the player's option. To change, the player only has to hold JUMP down .

FIRST STAGE: On the ground, the player shoots mines with his laser gun and destroys HELA tanks with an energy blast. In the air, he shoots down enemy fighters and floating mines crowded behind clouds.

In the aero-fighter form only, energy fuel is used. AEROBOTO should be converted to a ROBOT before the fuel runs out. (Remaining fuel is indicated on the lower-right side of the screen.)

Energy cores appear occasionally on the ground. The player can retrieve them for refueling (10 points). AEROBOTO can also pick up an energy core as it's flying low above the ground.

SECOND STAGE: AEROBOTO should fly over the ocean as an AERO-FIGHTER, avoiding attacks by anti-aircraft missiles. AEROBOTO must reserve at least 50 points of fuel to fly over the ocean.

THIRD STAGE: At the desert...besides enemies in first-stage mobile strongholds, LAND-WALKERS are on watch for AEROBOTO. Destroy LAND-WALKERS by hitting them with energy blasts to the head. AEROBOTO can sneak between the legs of LAND-WALKERS. From the air...torpedo planes throw bombs.

FOURTH STAGE: Again flying over open ocean, destroy the enemy SPACE BATTLE-STAR with an energy blast. Now the COSMO-BOOSTER appears. Players control their AERO-FIGHTER with their joystick to dock before fuel is exhausted, and then launch into outer space.

FIFTH STAGE: At the unknown floating continent, fight against invading cosmic fighters and attacking units.

SIXTH STAGE: In outer space, the ultimate hidden evil fortress appears. It's being escorted by guard ships. Destroy the fortress and ships by hitting each in the center with an energy blast. One game round is over. The next round is a repeat, but at a higher skill level. Remaining fuel points are added to bonus points.

GAME OPERATION

GAME START

INSERT COINS. The game allocates an adjustable number of credits per coin and displays this number on the CRT. Factory settings are one credit per quarter. Players are allowed to buy in (continue on the last wave they played) for an additional quarter. At factory settings, when two credits are displayed, pressing 2-PLAYER START initiates a two-player game.

PLAY CONTROLS

- FIRE button - Operates the laser gun. Keep it pressed to convert the button to an Energy-Blast control.
- JUMP button - Operates JUMP. When button is held down it TRANSFORMS AEROBOTO from an AERO-FIGHTER to a ROBOT or back.
- Joystick - Controls gun movement, AERO-FIGHTER and ROBOT direction.

An extra AEROBOTO is awarded at 30,000 points, 100,000 points and every additional 100,000 points.

. EASEL

Fold and assemble the easel and apply the hot new game decal enclosed in this kit. Place easel on top of finished game to attract attention and increase earnings.

OPTIMIZE YOUR PROFITS!

THOROUGH RESEARCH has shown that two and a half minute games both satisfy players and also keep the quarters flowing.

If games aren't running about two and a half minutes long, then collections probably aren't at their peak. You'll want to tailor your game to your location. The trick is to adjust a few dip switches. (See the chart in this book.) It's easy, and WILLIAMS games let you do it!



WARNINGS & NOTICES

WARNING

This kit is intended for use only on coin operated video games manufactured after January 1, 1983, which have been verified for compliance with the requirements in Part 15 of FCC Rules for Class A computing device. Improper connection of this kit or connection to any other coin operated video game not so manufactured or verified for compliance may cause unacceptable interference to radio and TV reception requiring the operator to take whatever steps are necessary to correct the interference. WILLIAMS ELECTRONICS, INC., takes no responsibility for kits improperly connected and those connected to games for which use is not intended.

WARNING

FOR SAFETY AND RELIABILITY, WILLIAMS does not recommend or authorize any substitute parts or modifications of WILLIAMS equipment.

USE OF NON-WILLIAMS PARTS and modifications of game circuitry may adversely affect game play, or may cause injuries.

SUBSTITUTE PARTS OR EQUIPMENT MODIFICATIONS may void FCC type-acceptance.

SINCE THIS GAME IS PROTECTED by Federal copyright, trademark and patent laws, unauthorized game-conversions may be illegal under Federal law.

THIS "CONVERSION" PRINCIPLE ALSO APPLIES to unauthorized facsimiles of WILLIAMS equipment, logos, designs, publications, assemblies and games (or game features not deemed to be in the public domain), whether manufactured with WILLIAMS components or not.

THREE-WIRE PLUG. This game must be plugged into a properly-grounded outlet to prevent shock hazard and to assure proper game operation. DO NOT use a "cheater" plug to defeat the ground pin on the power cord, and DO NOT cut off the ground pin.

NOTICE

AEROBOTO is a registered trademark of WILLIAMS ELECTRONICS, INC.

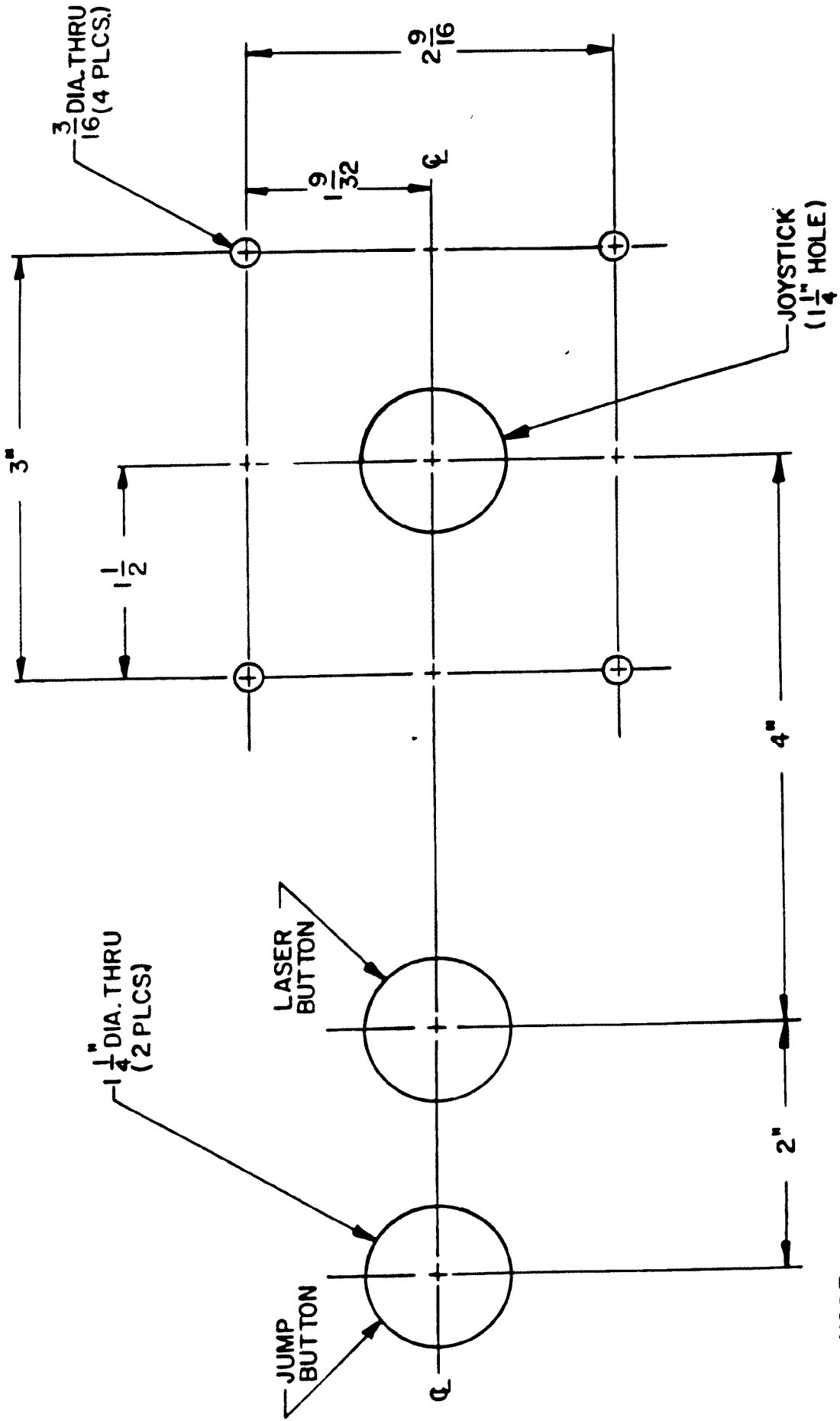

**NOTE:**  
 THESE DIMENSIONS ARE FOR YOUR  
 REFERENCE ONLY.

# CONTROL PLATE TEMPLATE